

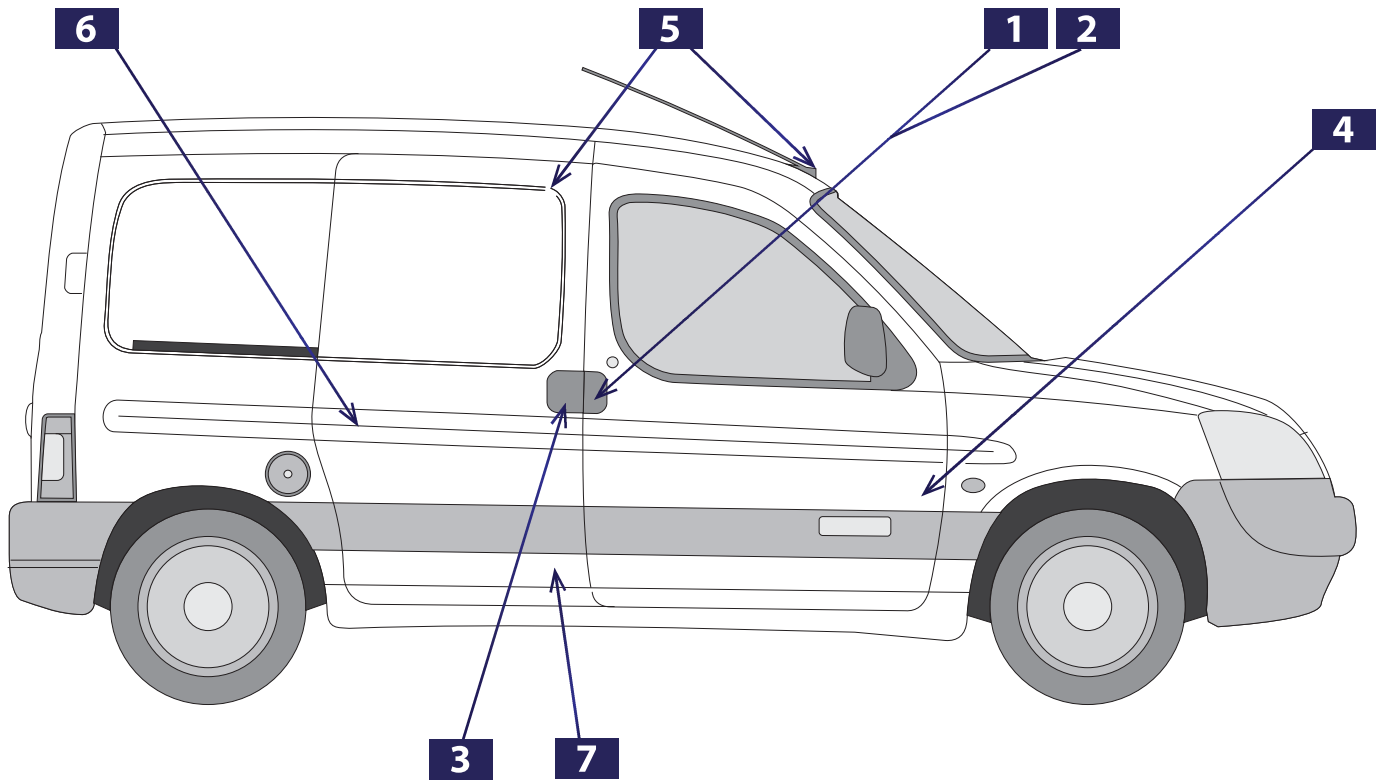

## PARTNER / RANCH



**1** FT94151



**2** FT94152



**3** FT94500



**4** FT95461



**5** FT95540



**6** FT95541



**7** FT95542



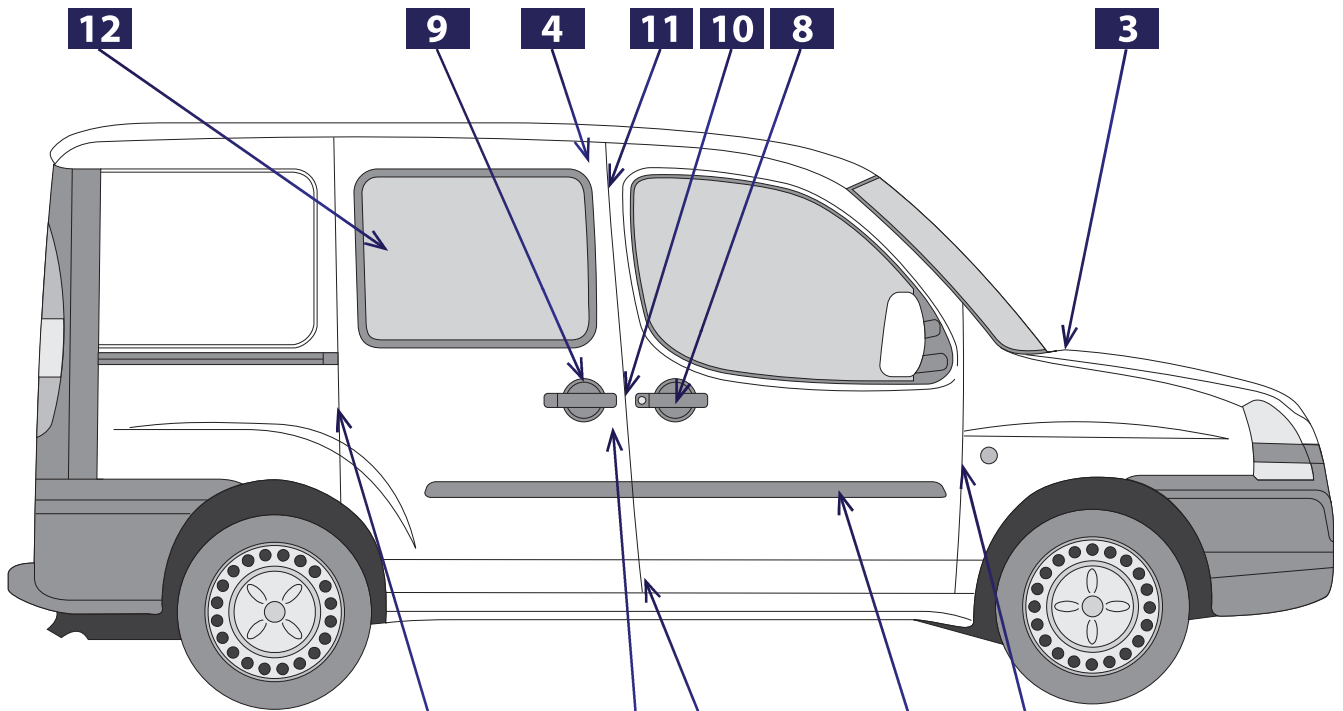

**1** FT90801 (RIGHT)   
 FT90800 (LEFT)

**5** **2** **6** **7** **1** **13**



**2** FT95400 (RIGHT)   
 FT95534 (LEFT)



**3** FT95464 (RIGHT)   
 FT95463 (LEFT)



**4** FT95566



**5** FT95567 (RIGHT)   
 FT95585 (LEFT)



**6** FT95569



FURGON

**7** FT95570



PANORAMA

**8** FT94376 (RIGHT)   
 FT94377 (LEFT)



**9** FT94378



**10** FT95339



**11** FT95405



**12** FT95407



**13** FT95337



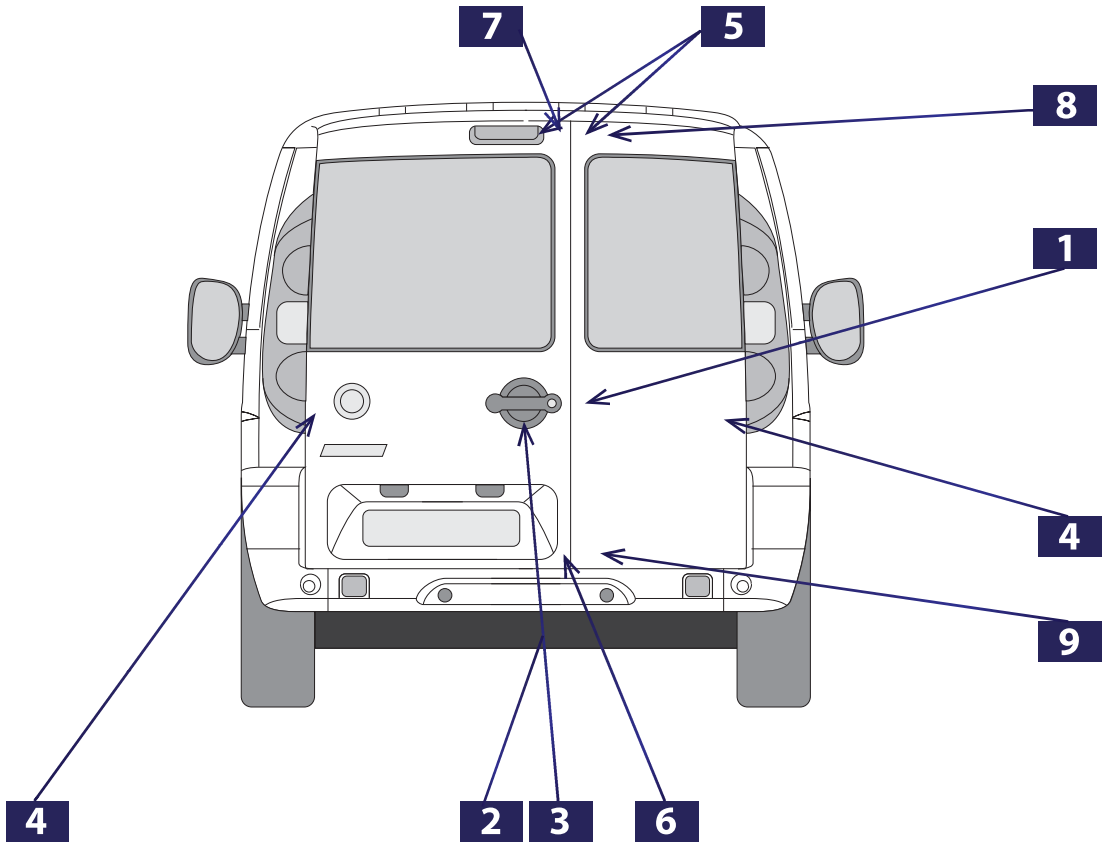

<p><b>1</b>   FT94551</p> 	<p><b>2</b>   FT94346</p> 	<p><b>3</b>   FT94547</p>  <p>CENTRAL LOCK</p>	<p><b>4</b>   FT95533</p> 
<p><b>5</b>   FT95467</p> 	<p><b>6</b>   FT95355</p> 	<p><b>7</b>   FT95353</p> 	<p><b>8</b>   FT95354</p> 
<p><b>9</b>   FT95356</p> 			



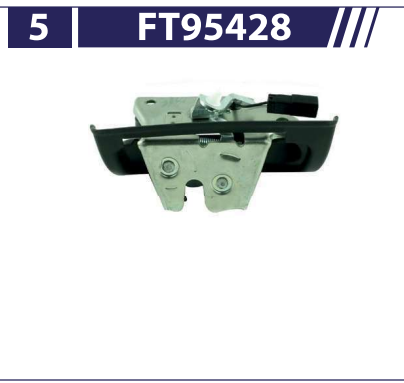
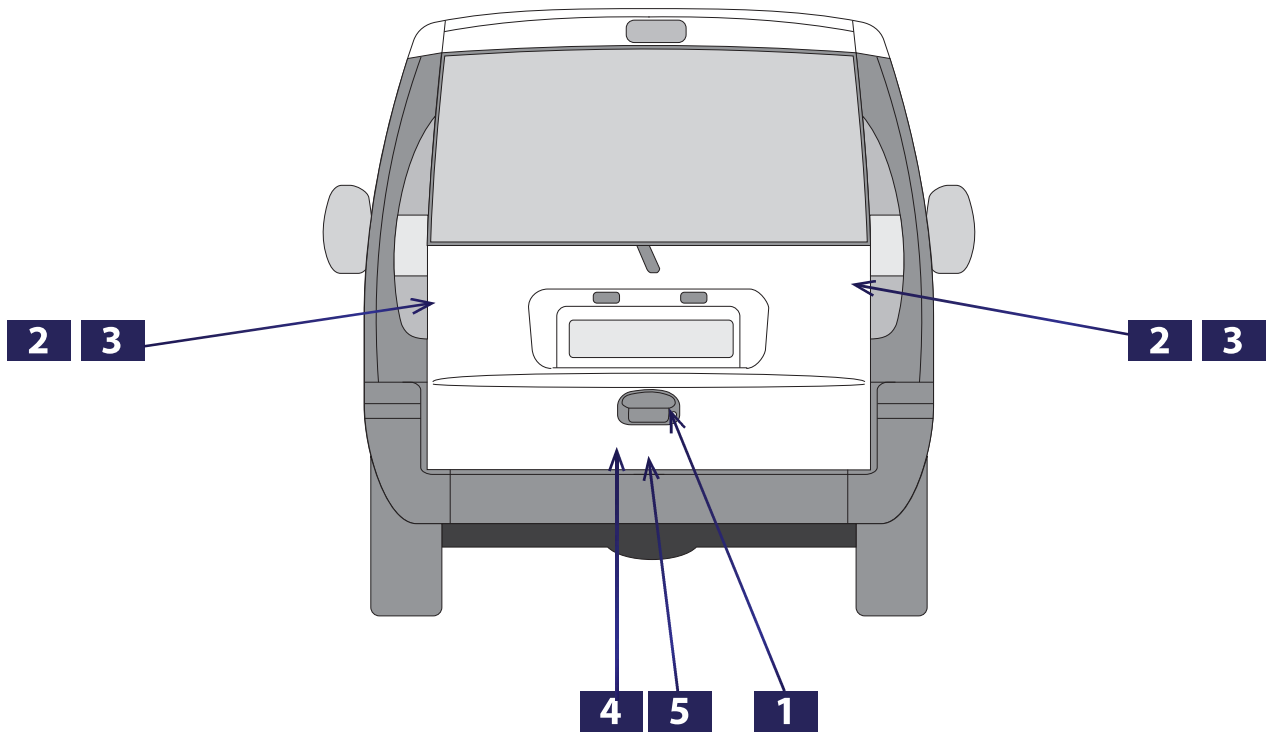

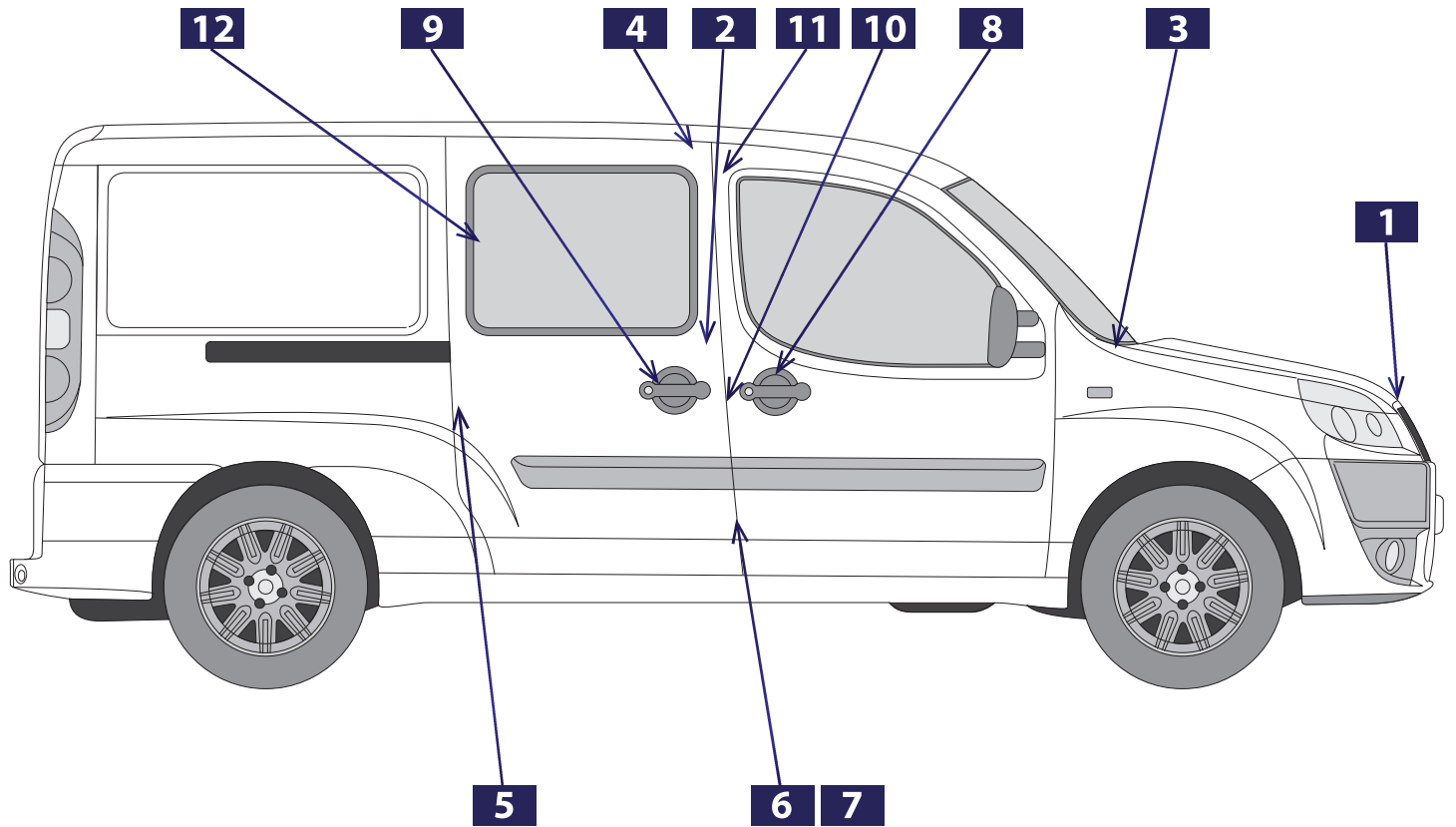

<b>1</b> FT94166 	<b>2</b> FT95400 (RIGHT) <b>FT95534</b> (LEFT) 	<b>3</b> FT95464 (RIGHT) <b>FT95463</b> (LEFT) 	<b>4</b> FT95566 
<b>5</b> FT95567 (RIGHT) <b>FT95585</b> (LEFT) 	<b>6</b> FT95569  <p style="text-align: right;">FURGON</p>	<b>7</b> FT95570  <p style="text-align: right;">PANORAMA</p>	<b>8</b> FT94376 (RIGHT) <b>FT94377</b> (LEFT) 
<b>9</b> FT94378 	<b>10</b> FT95339 	<b>11</b> FT95405 	<b>12</b> FT95407 

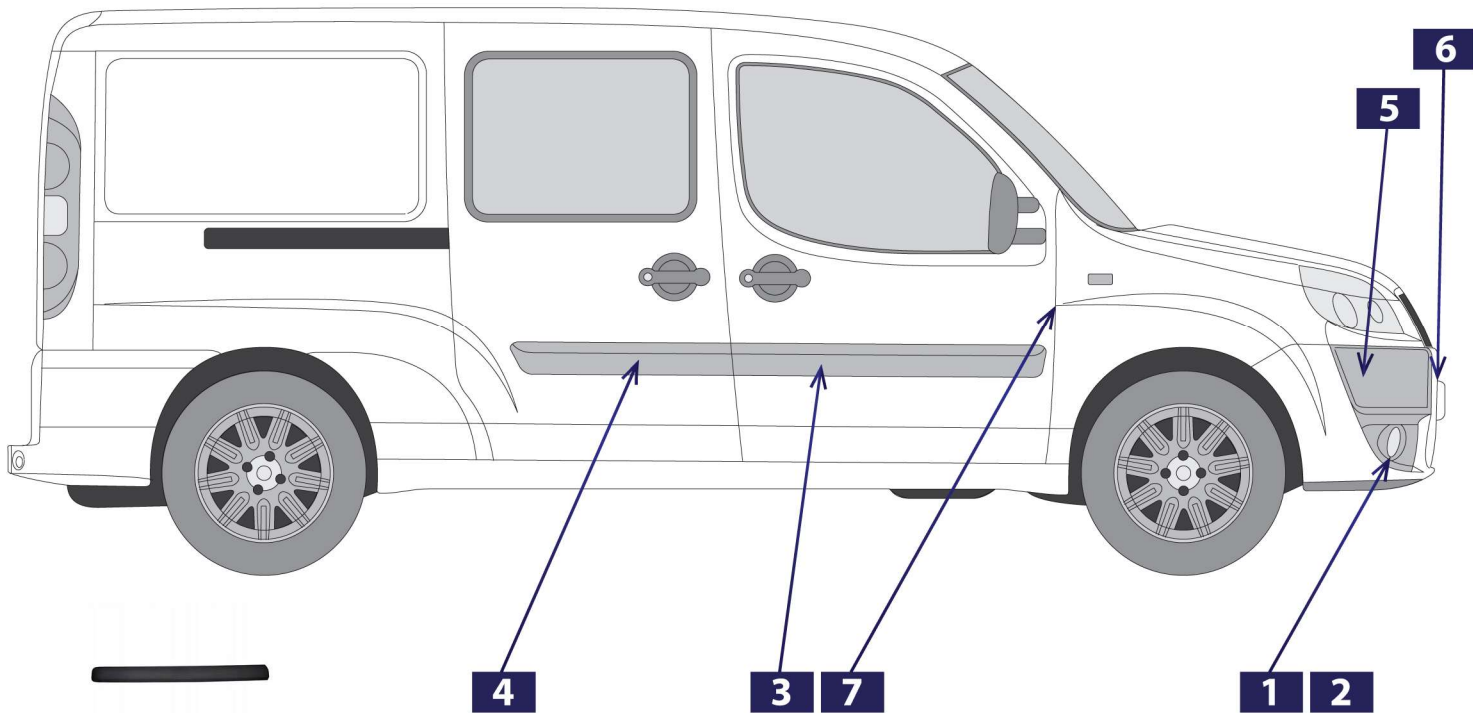

**1** FT91644 (RIGHT) //  
FT91643 (LEFT) //



**2** FT91634 (RIGHT) //  
FT91633 (LEFT) //



**3** FT90741 (RIGHT) //  
FT90732 (LEFT) //



**4** FT90734 (RIGHT) //  
FT90733 (LEFT) //

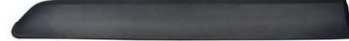

**5** FT90740 (RIGHT) //  
FT90739 (LEFT) //



**6** FT90817 //



**7** FT95564 //



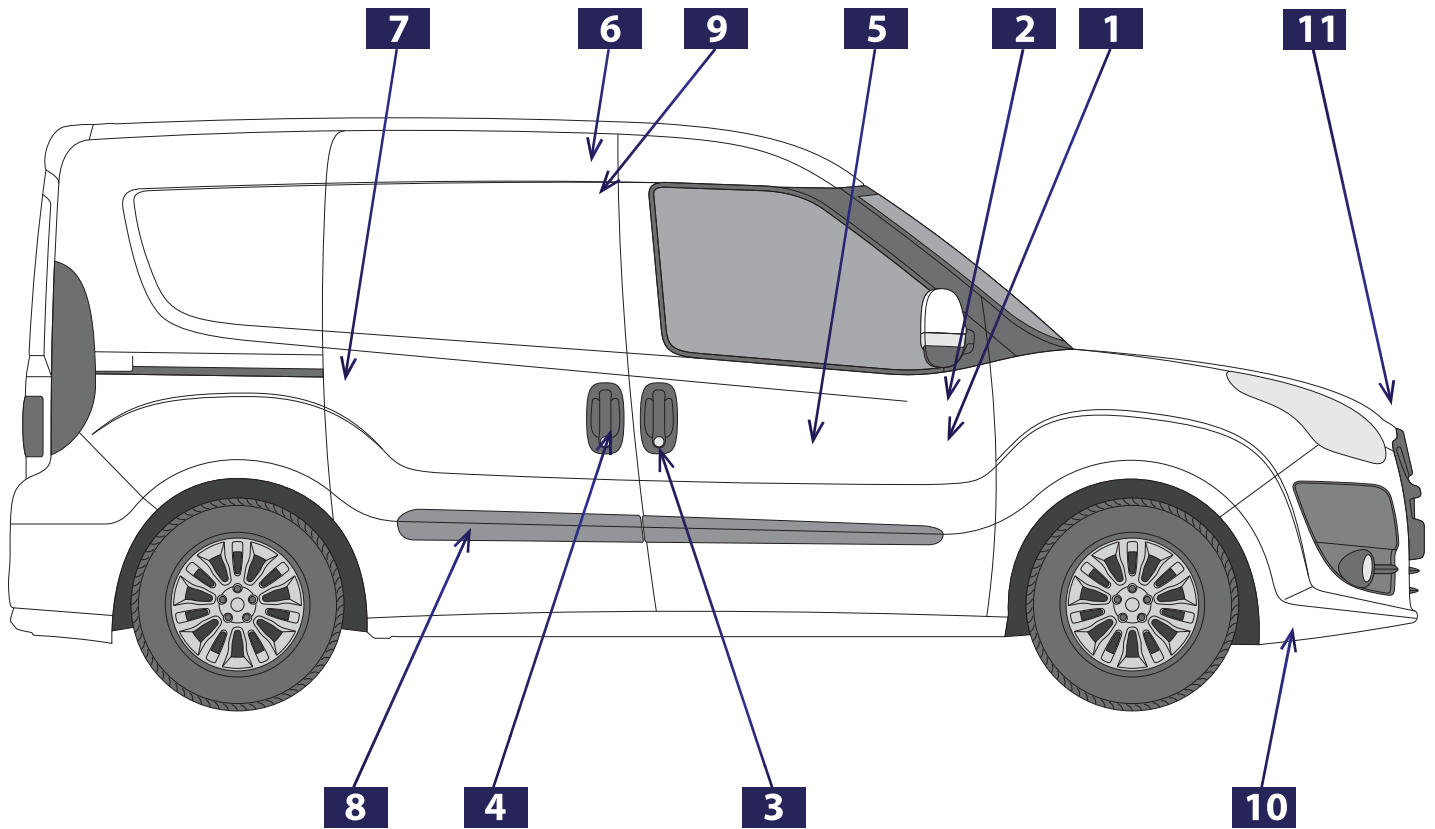

<b>1</b>   <b>FT95378</b> 	<b>2</b>   <b>FT95406</b> 	<b>3</b>   <b>FT94554</b> 	<b>4</b>   <b>FT94576</b>  RIGHT/ SLIDING DOOR
<b>5</b>   <b>FT94580</b> (RIGHT)  <b>FT94575</b> (LEFT)	<b>6</b>   <b>FT95587</b> (RIGHT)  <b>FT95589</b> (LEFT)	<b>7</b>   <b>FT95591</b>  RIGHT	<b>8</b>   <b>FT90803</b> (RIGHT)  <b>FT90802</b> (LEFT)
<b>9</b>   <b>FT95405</b> 	<b>10</b>   <b>FT99004</b> 	<b>11</b>   <b>FT94164</b> 	

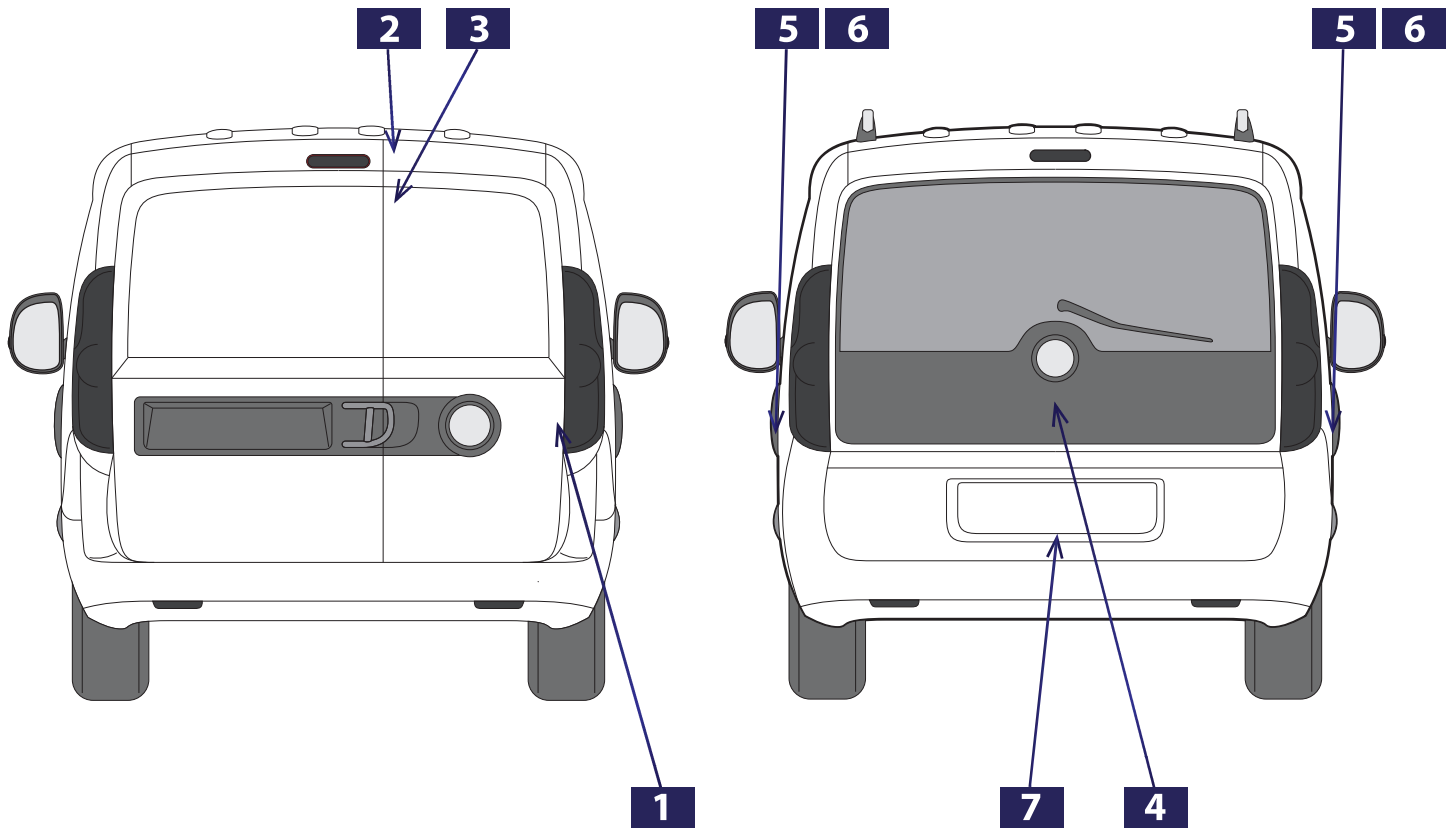

<b>1</b>   <b>FT95398</b>	<b>2</b>   <b>FT95531</b>	<b>3</b>   <b>FT95354</b>	<b>4</b>   <b>FT95430</b>
<b>5</b>   <b>FT95465</b>	<b>6</b>   <b>FT95466</b>	<b>7</b>   <b>FT95468</b>	

## Boxer / Jumper

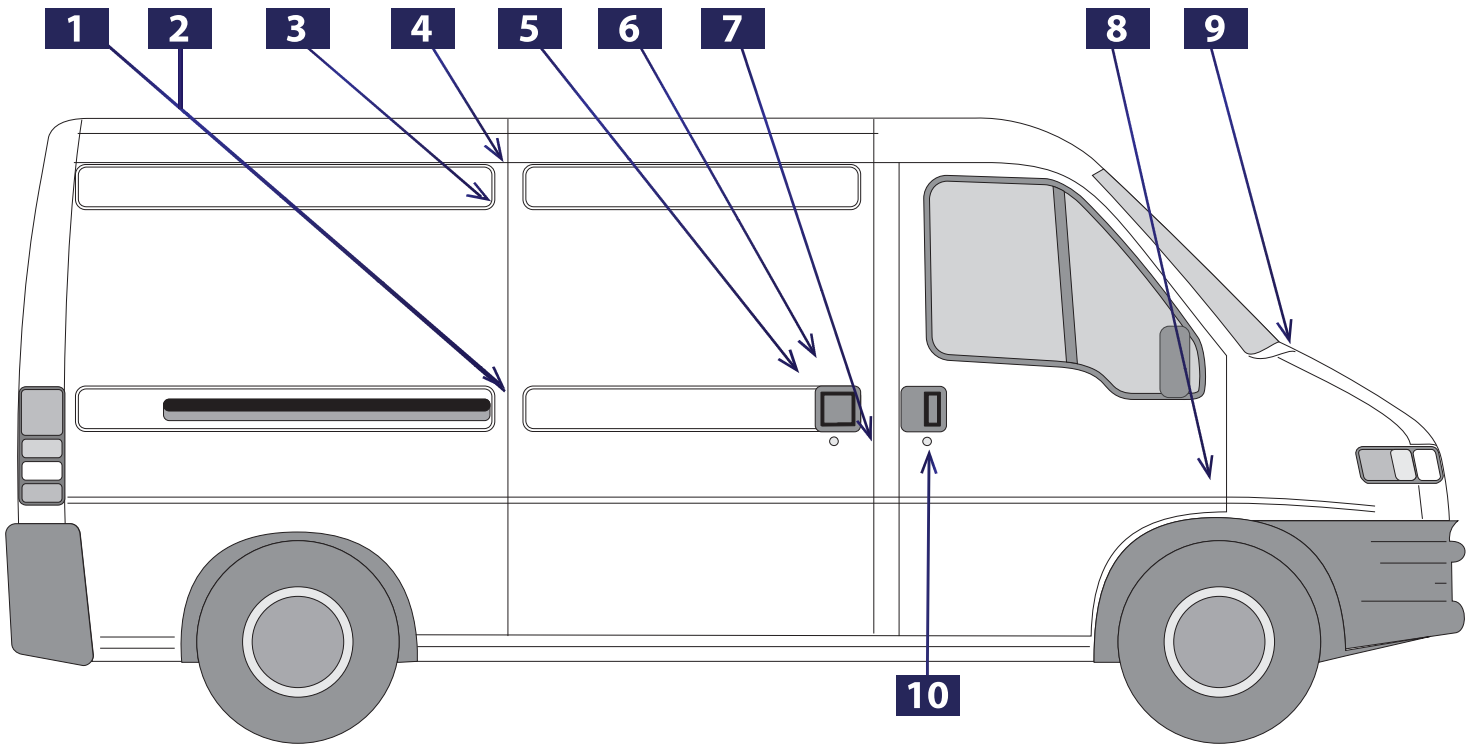

<p><b>1</b> FT95252</p>	<p><b>2</b> FT95252Z</p>	<p><b>3</b> FT95211</p>	<p><b>4</b> FT95207</p>
<p><b>5</b> FT94434</p>	<p><b>6</b> FT94242</p>	<p><b>7</b> FT95064</p>	<p><b>8</b> FT95358</p>
<p><b>9</b> FT93311</p>	<p><b>10</b> FT94107</p>		



## Boxer / Jumper

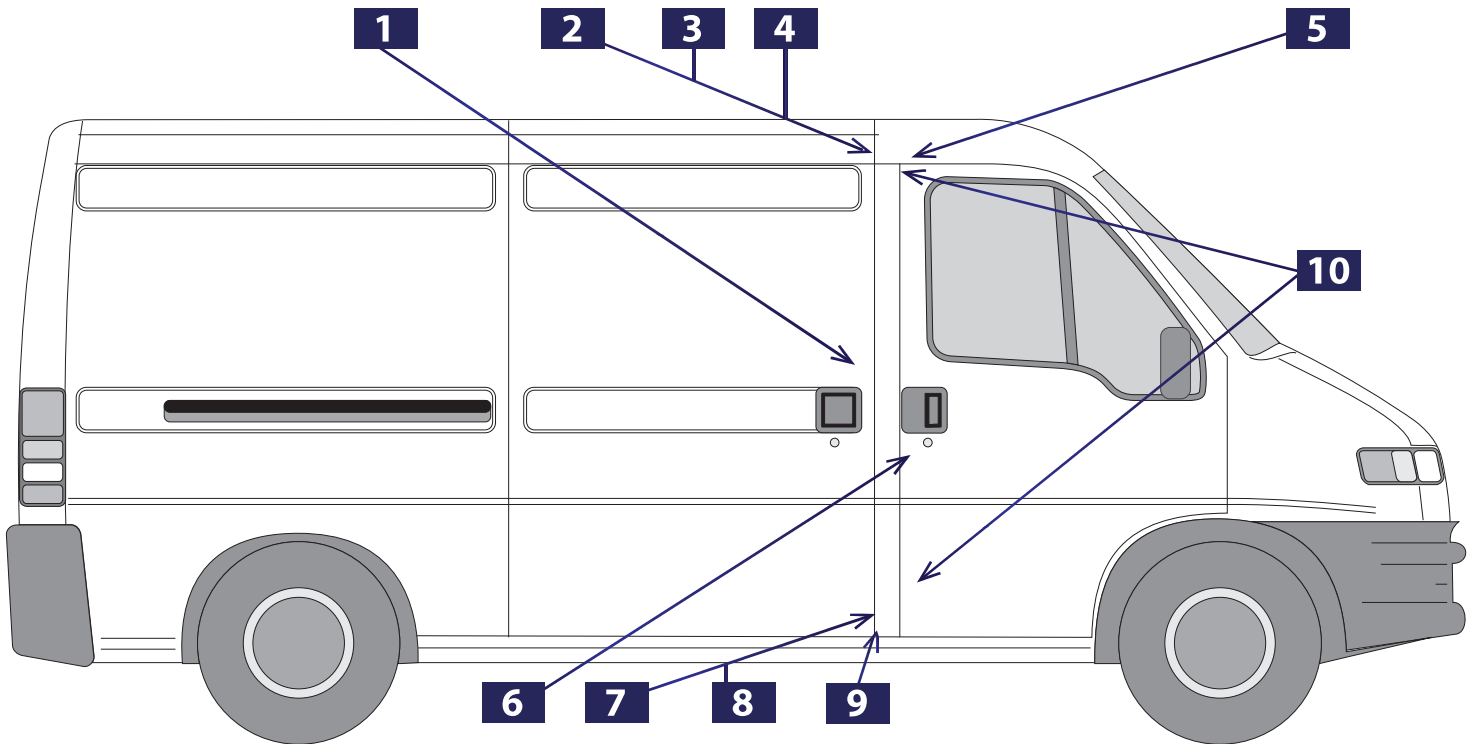

<p><b>1</b> FT95206</p>  <p>RIGHT / LEFT</p>	<p><b>2</b> FT95250Z</p> 	<p><b>3</b> FT95250B</p> 	<p><b>4</b> FT95250</p> 
<p><b>5</b> FT95208</p>  <p>UPPER</p>	<p><b>6</b> FT95205</p>  <p>RIGHT / LEFT</p>	<p><b>7</b> FT95251</p> 	<p><b>8</b> FT95251Z</p> 
<p><b>9</b> FT95209</p>  <p>LOWER</p>	<p><b>10</b> FT95210</p> 		

## Boxer / Jumper

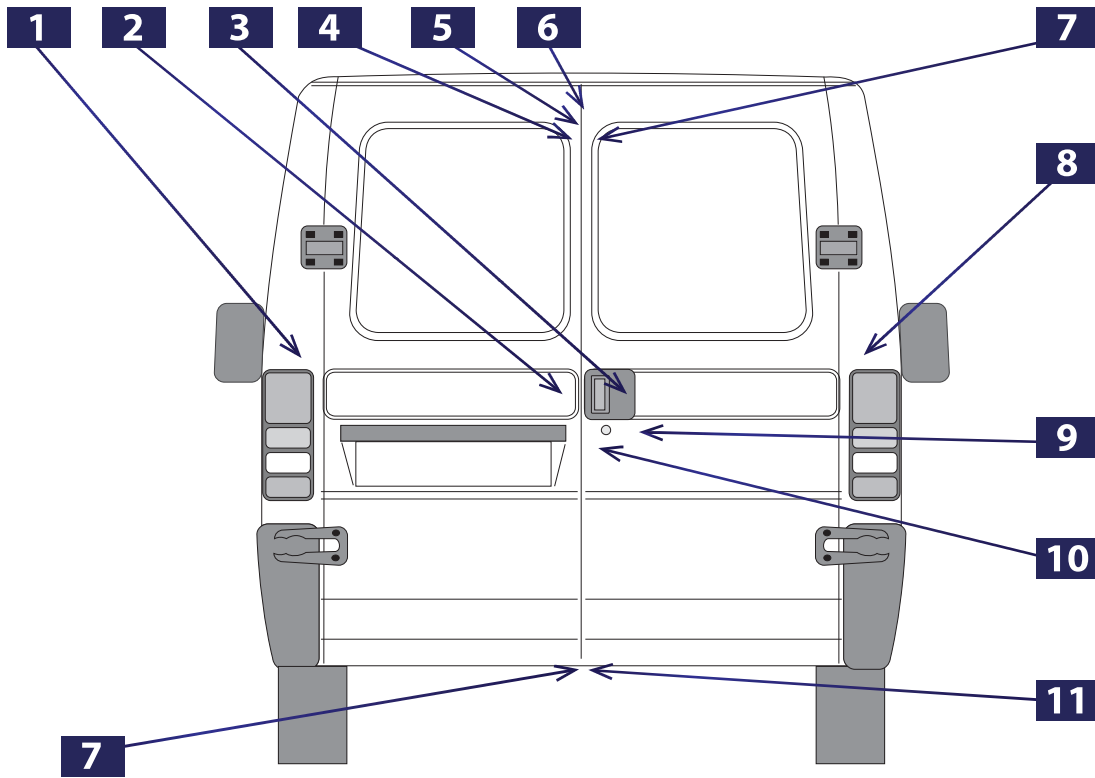

**1** FT95296

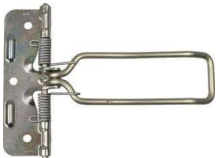

RIGHT / LEFT

**2** FT95205



**3** FT94243



**4** FT95207



**5** FT95213

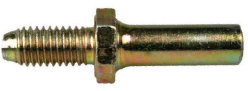

**6** FT95298



**7** FT95334



**8** FT95296



RIGHT / LEFT

**9** FT94107



**10** FT95065



**11** FT95299



## Boxer / Jumper

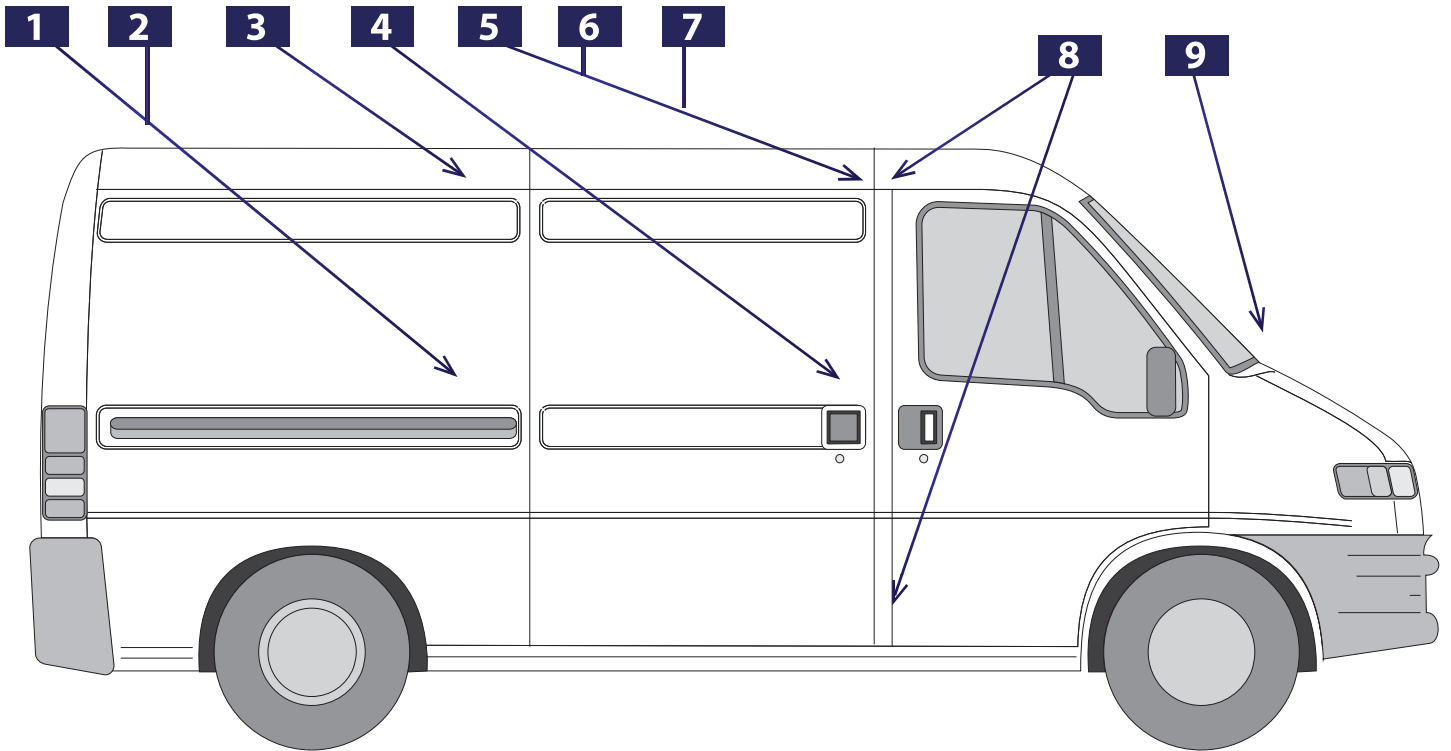

<p><b>1</b> FT95310</p>	<p><b>2</b> FT95252Z</p>	<p><b>3</b> FT95338</p>	<p><b>4</b> FT95206</p> <p>RIGHT / LEFT</p>
<p><b>5</b> FT95250Z</p>	<p><b>6</b> FT95250B</p>	<p><b>7</b> FT95250</p>	<p><b>8</b> FT95210</p>
<p><b>9</b> FT95409 FT95408</p> <p>RIGHT / LEFT</p>			

## Boxer / Jumper

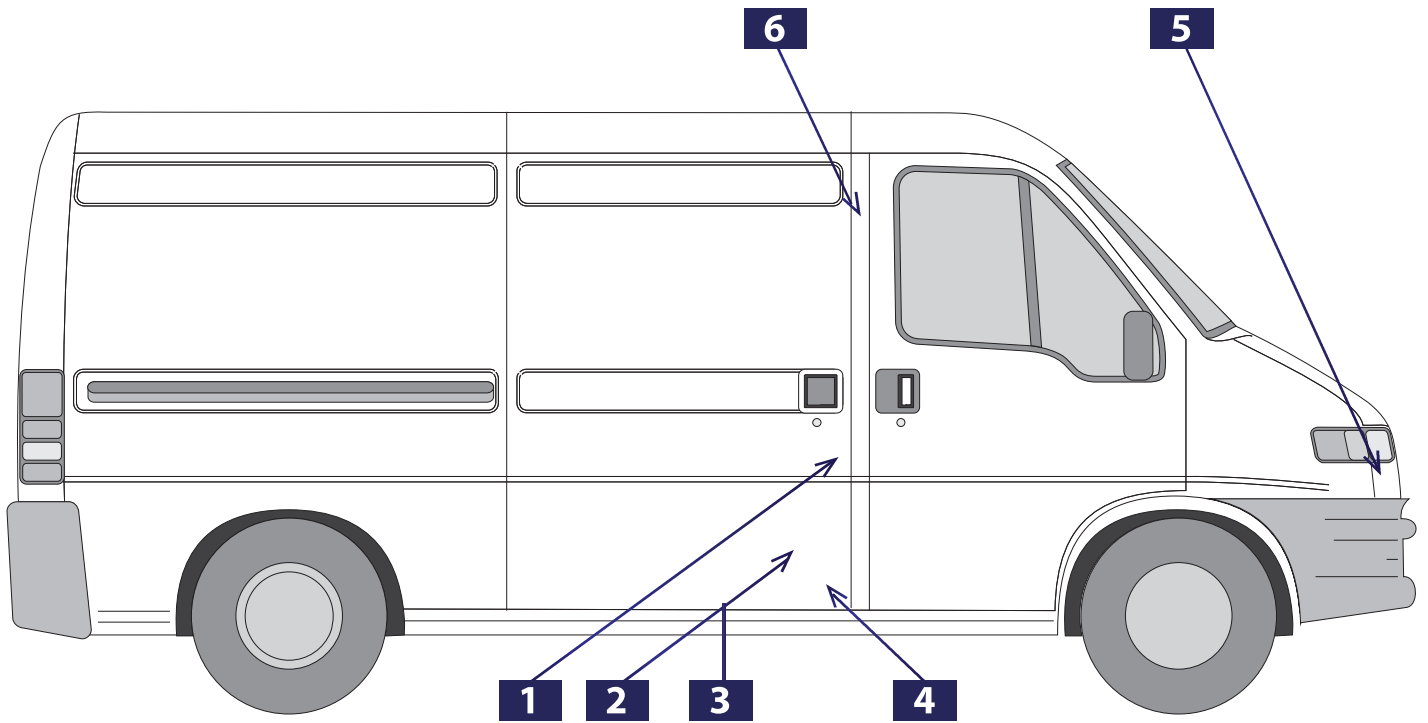

<p><b>1</b> FT95205</p>  <p>RIGHT / LEFT</p>	<p><b>2</b> FT95512</p> 	<p><b>3</b> FT95251Z</p> 	<p><b>4</b> FT95209</p>  <p>LOWER</p>
<p><b>5</b> FT94148</p> 	<p><b>6</b> FT95208</p>  <p>UPPER</p>		

## Boxer / Jumper

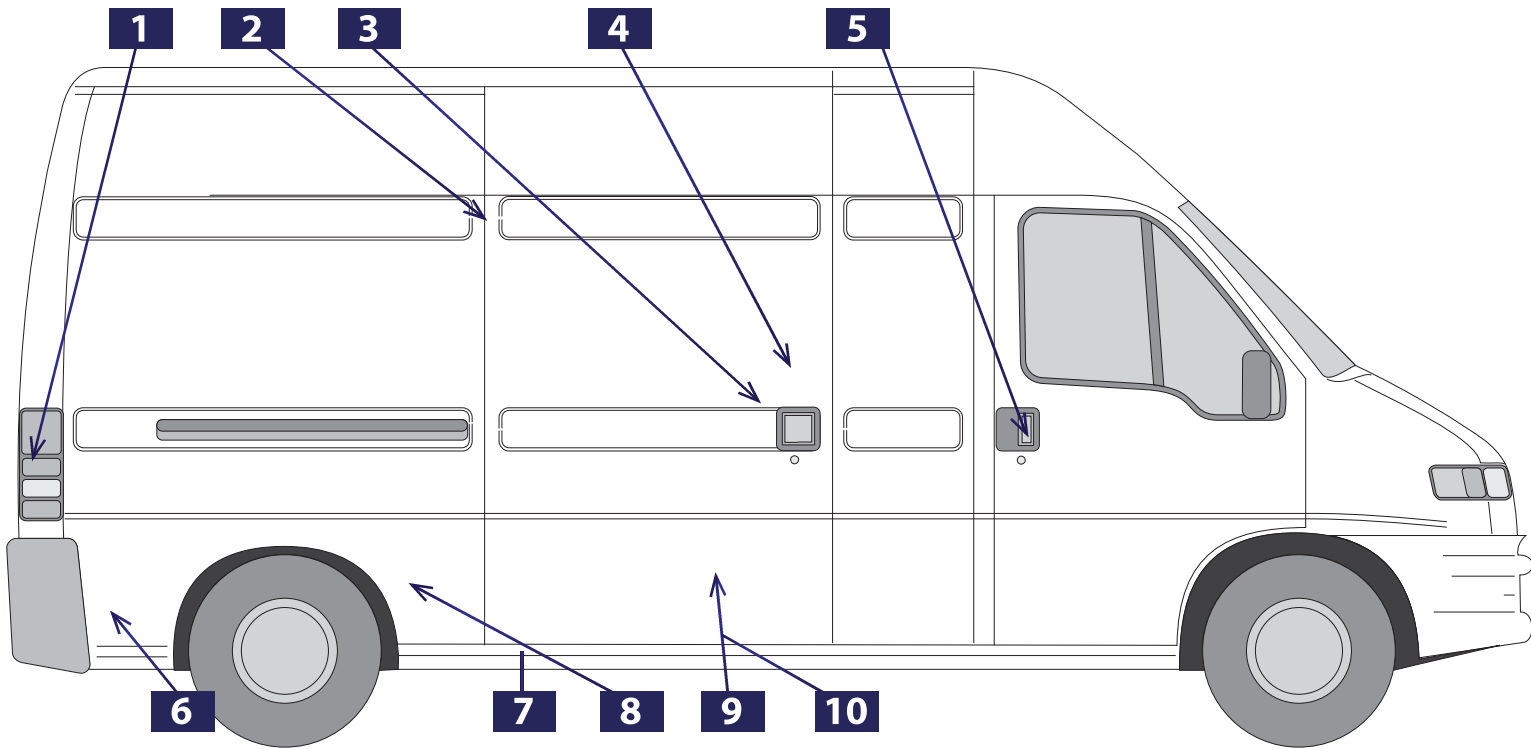

<p><b>1</b> FT90797 FT90798</p>  <p>RIGHT / LEFT</p>	<p><b>2</b> FT95095</p> 	<p><b>3</b> FT95064</p> 	<p><b>4</b> FT94509</p> 
<p><b>5</b> FT94342</p>  <p>RIGHT / LEFT</p>	<p><b>6</b> FT90738 (RIGHT) FT90737 (LEFT)</p> 	<p><b>7</b> FT90793 (RIGHT) FT90794 (LEFT)</p>  <p>SHORT</p>	<p><b>8</b> FT90791 (RIGHT) FT90792 (LEFT)</p>  <p>MIDDLE / LONG</p>
<p><b>9</b> FT90790</p>  <p>SHORT</p> <p>RIGHT / LEFT</p>	<p><b>10</b> FT90789</p>  <p>MIDDLE / LONG</p> <p>RIGHT / LEFT</p>		

## Boxer / Jumper

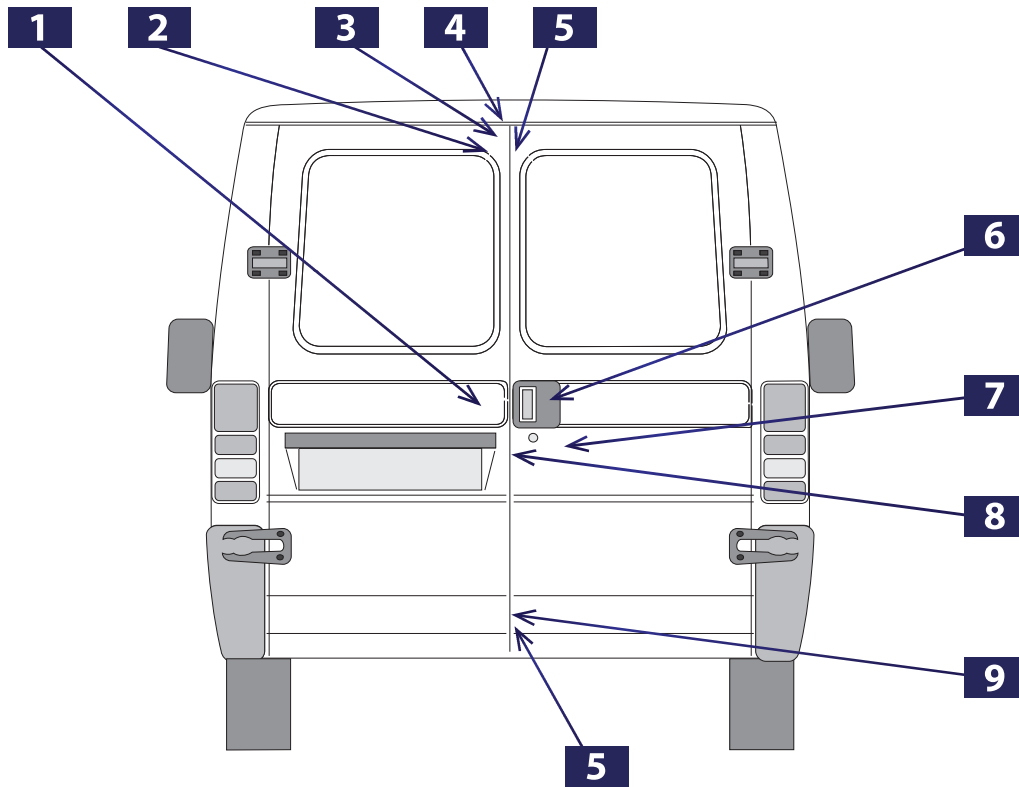

**1** FT95205



**2** FT95095



**3** FT95365



**4** FT95298



**5** FT95334



**6** FT94343



**7** FT94130



**8** FT95065



**9** FT95299





## Boxer / Jumper

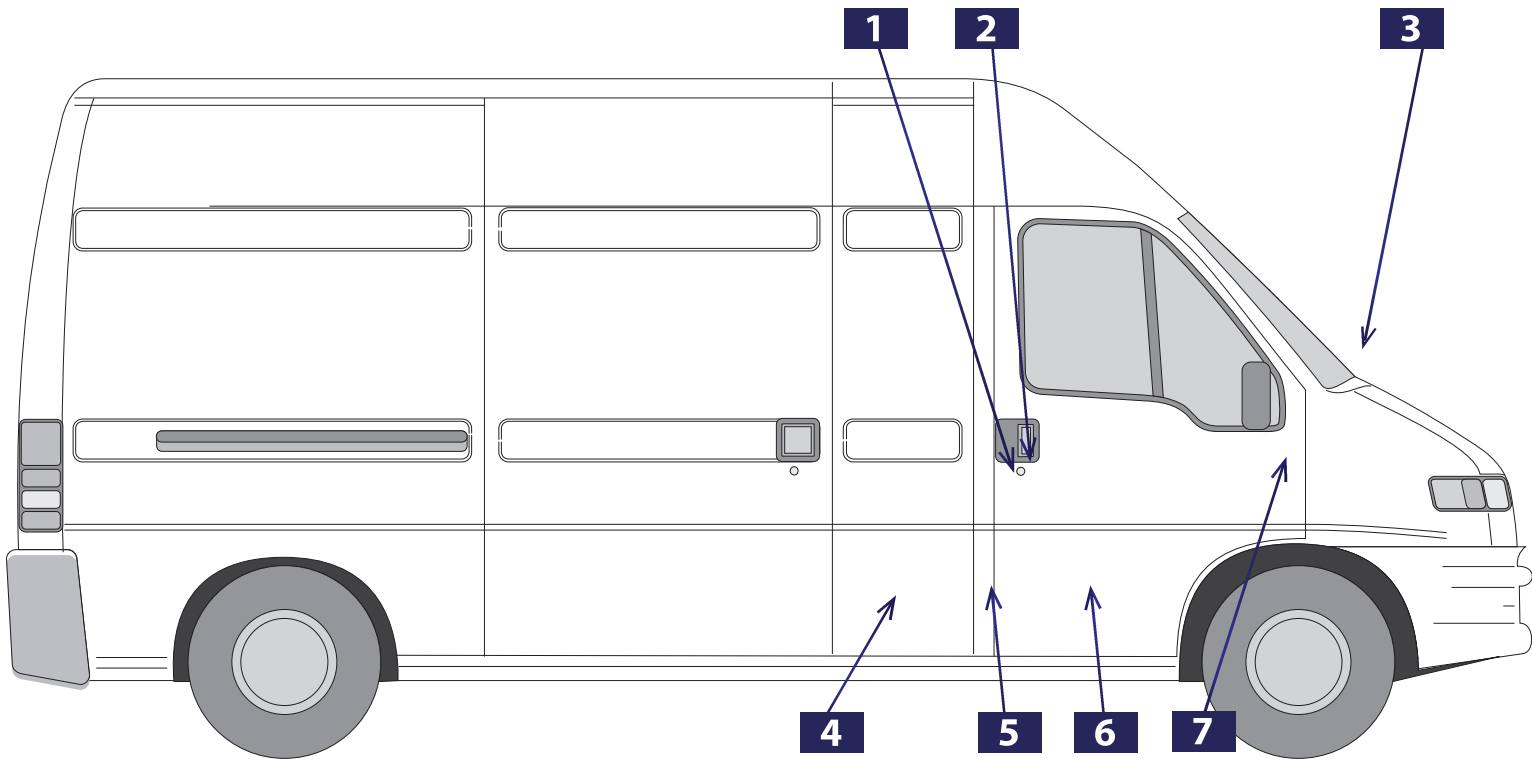

<p><b>1</b> FT95093 (RIGHT) // FT95092 (LEFT) //</p> 	<p><b>2</b> FT94130 //</p> 	<p><b>3</b> FT93313 //</p>  <p>RIGHT / LEFT</p>	<p><b>4</b> FT90788 //</p> 
<p><b>5</b> FT90799 //</p> 	<p><b>6</b> FT90786 (RIGHT) // FT90787 (LEFT) //</p> 	<p><b>7</b> FT95357 //</p>  <p>RIGHT / LEFT</p>	

## Boxer / Jumper

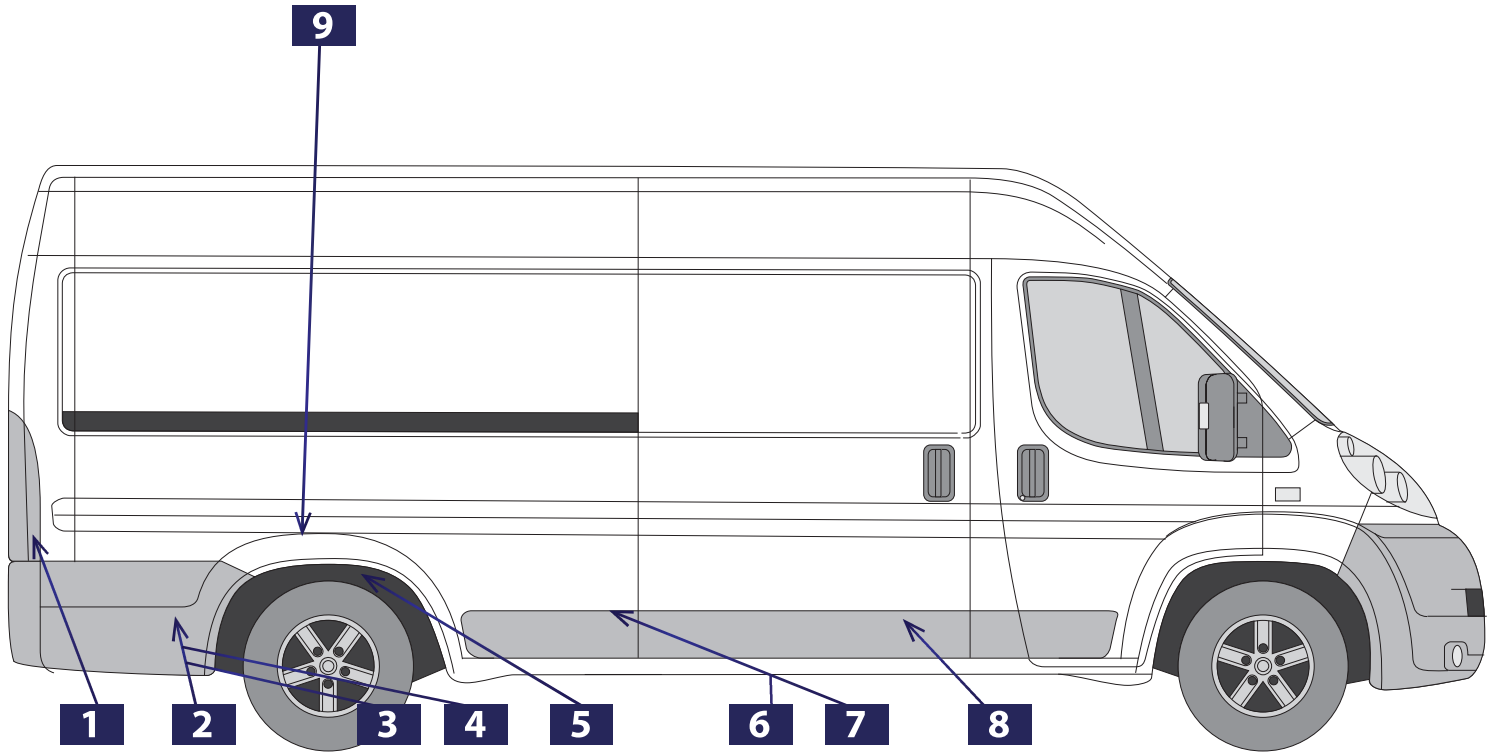

**1** FT90764 (RIGHT) //  
FT90765 (LEFT) //



**2** FT90776 (RIGHT) //  
FT90779 (LEFT) //



**3** FT90777 (RIGHT) //  
FT90780 (LEFT) //



MAXI

**4** FT90778 (RIGHT) //  
FT90781 (LEFT) //



EXTRA LONG

**5** FT90528 (RIGHT) //  
FT90529 (LEFT) //



**6** FT90757 (RIGHT) //  
FT90758 (LEFT) //



**7** FT90770 (RIGHT) //  
FT90771 (LEFT) //



MAXI

**8** FT90748 (RIGHT) //  
FT90759 (LEFT) //



**9** FT90751 (RIGHT) //  
FT90752 (LEFT) //



MAXI

## Boxer / Jumper

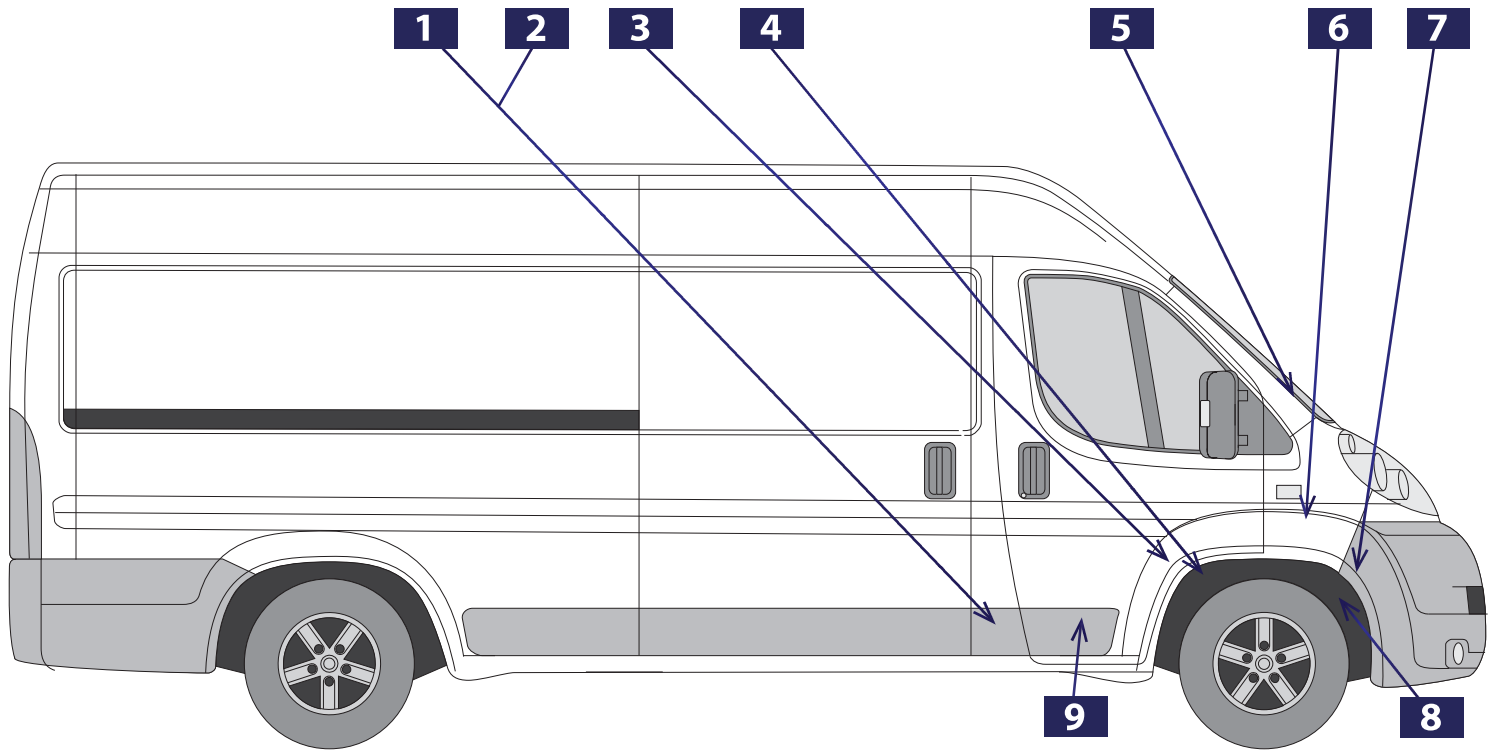

**1** FT90760 (RIGHT) //  
FT90762 (LEFT) //



**2** FT90761 (RIGHT) //  
FT90763 (LEFT) //



MAXI

**3** FT90755 (RIGHT) //  
FT90756 (LEFT) //



HEAVY

**4** FT90772 (RIGHT) //  
FT90773 (LEFT) //



MAXI

**5** FT90775 (RIGHT) //  
FT90774 (LEFT) //



**6** FT90749 (RIGHT) //  
FT90750 (LEFT) //



MAXI

**7** FT90766 (RIGHT) //  
FT90767 (LEFT) //



MAXI

**8** FT90526 (RIGHT) //  
FT90527 (LEFT) //



**9** FT90753 (RIGHT) //  
FT90754 (LEFT) //



## Boxer / Jumper

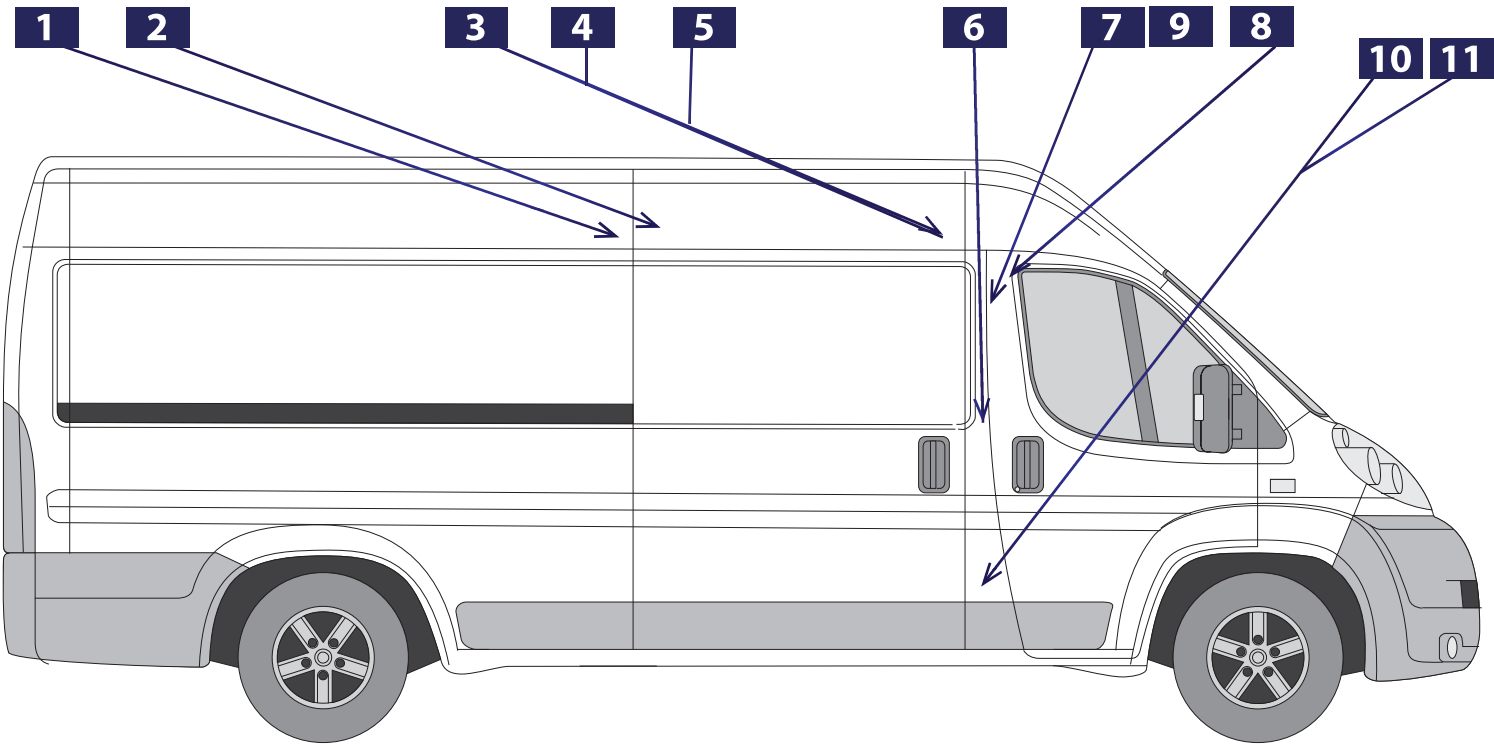

<b>1</b>   <b>FT95376</b>  	<b>2</b>   <b>FT95340</b>  	<b>3</b>   <b>FT95371</b>  	<b>4</b>   <b>FT95387</b>  
<b>5</b>   <b>FT95350</b>  	<b>6</b>   <b>FT95361</b>  	<b>7</b>   <b>FT95208</b>   -> 2012.08	<b>8</b>   <b>FT95210</b>   -> 2012.08
<b>9</b>   <b>FT95416</b>   2012.08 ->	<b>10</b>   <b>FT95415</b>   2012.08 ->	<b>11</b>   <b>FT95209</b>   -> 2012.08	

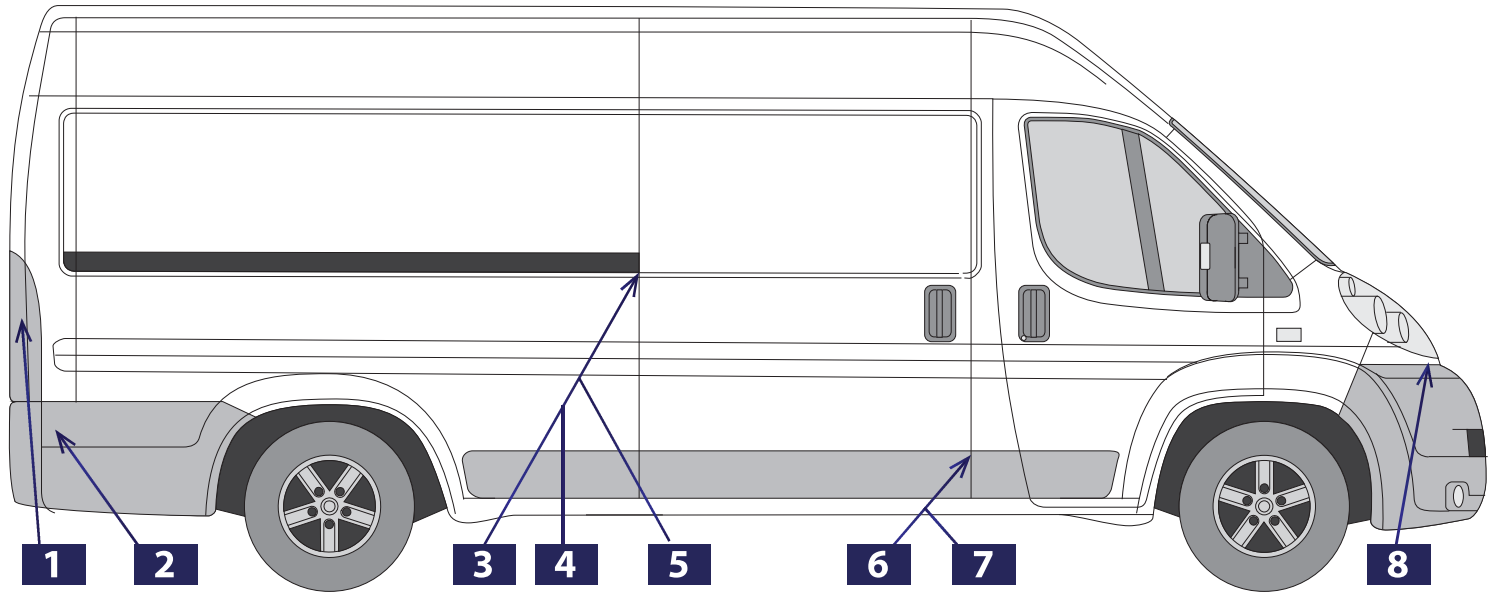

**1** FT95377



**2** FT95359



LOW

**3** FT95373



**4** FT95388



**5** FT95352



**6** FT95351



**7** FT95389

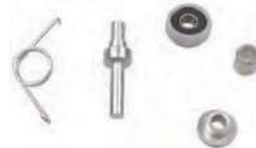

**8** FT94150



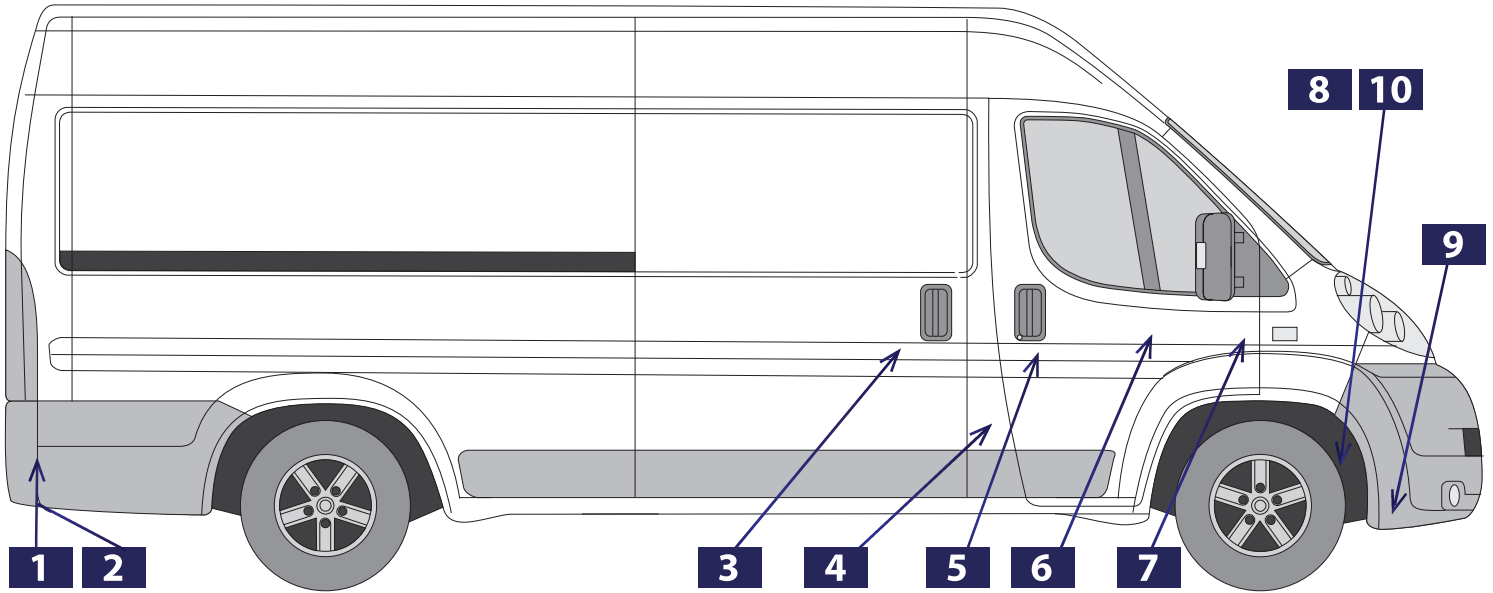

<p><b>1</b> FT91444 (RIGHT) // FT91443 (LEFT) //</p>  <p>MAXI</p>	<p><b>2</b> FT91446 (RIGHT) // FT91445 (LEFT) //</p> 	<p><b>3</b> FT94389 //</p>  <p>RIGHT / LEFT</p>	<p><b>4</b> FT90785 //</p> 
<p><b>5</b> FT94390 (RIGHT) // FT94391 (LEFT) //</p> 	<p><b>6</b> FT94542 (RIGHT) // FT94541 (LEFT) //</p> 	<p><b>7</b> FT95379 //</p>  <p>RIGHT / LEFT</p>	<p><b>8</b> FT90783 //</p>  <p>LEFT</p>
<p><b>9</b> FT90784 //</p>  <p>CENTRAL</p>	<p><b>10</b> FT90782 //</p>  <p>RIGHT</p>		



## Boxer / Jumper

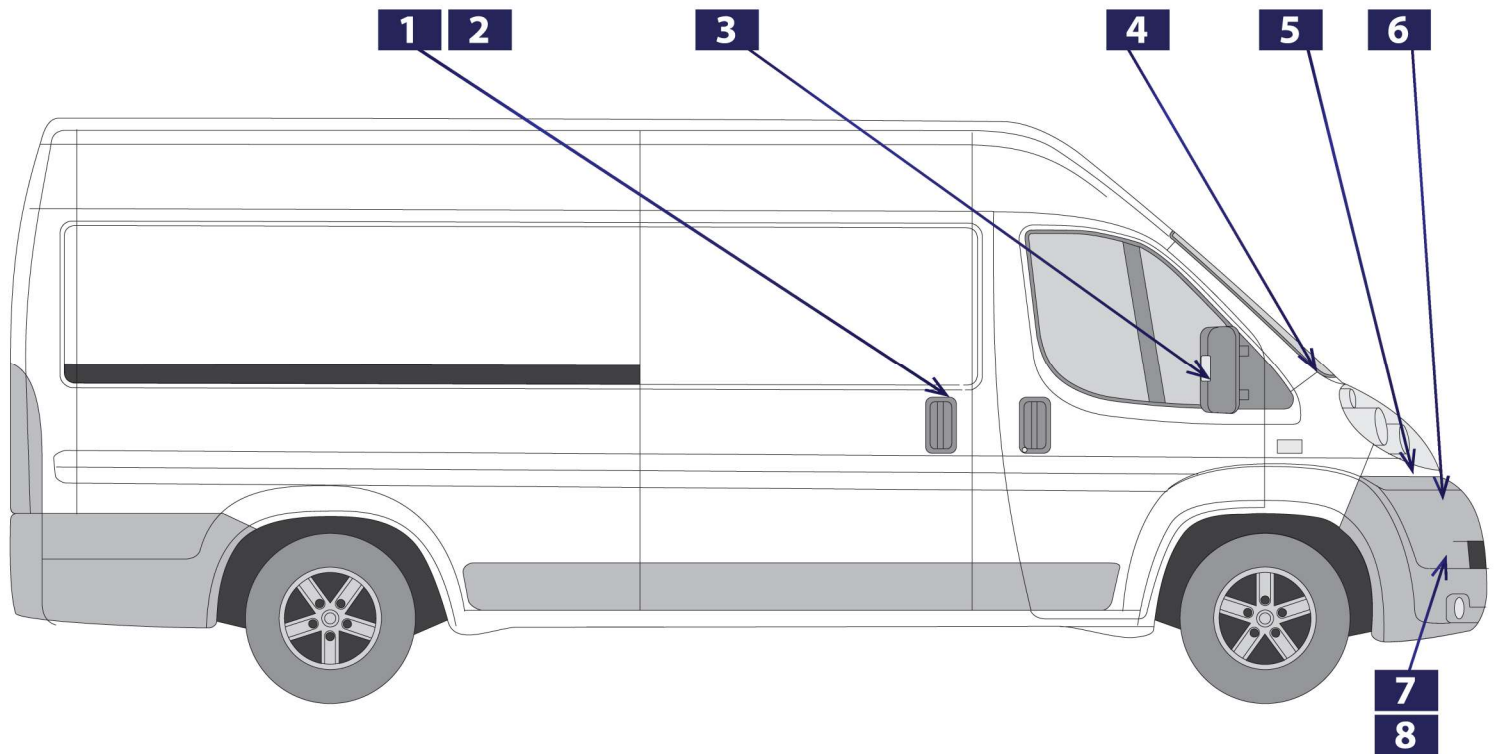

<p><b>1</b> FT94539</p>  <p>RIGHT</p>	<p><b>2</b> FT94540</p>  <p>RIGHT / LEFT</p>	<p><b>3</b> FT86041 (RIGHT) FT86040 (LEFT)</p> 	<p><b>4</b> FT90745 (RIGHT) FT90744 (LEFT)</p> 
<p><b>5</b> FT90747 (RIGHT) FT90746 (LEFT)</p> 	<p><b>6</b> FT91639</p> 	<p><b>7</b> FT91447 (RIGHT) FT91448 (LEFT)</p>  <p>SENZA FORI MODANATURA</p>	<p><b>8</b> FT91450 (RIGHT) FT91449 (LEFT)</p>  <p>HEAVY CON FORI MODANATURA</p>

## Boxer / Jumper

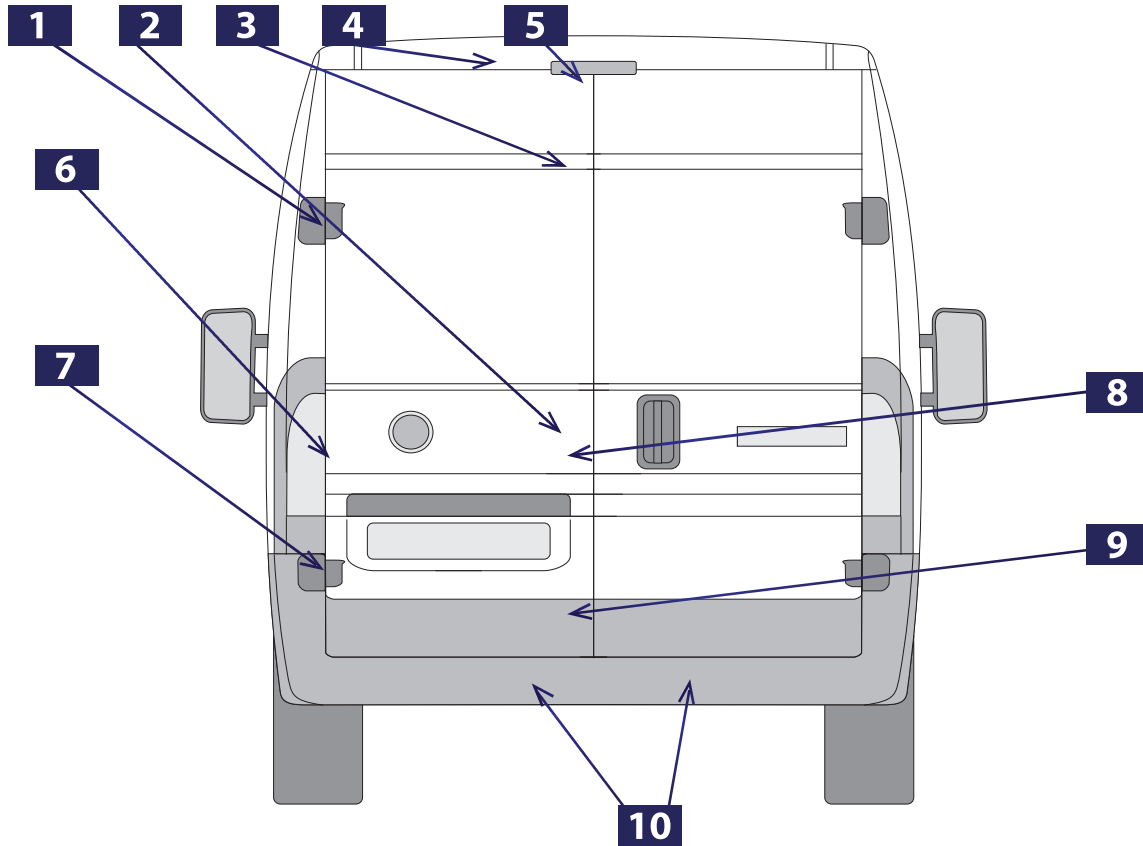

<p><b>1</b> FT95411</p> 	<p><b>2</b> FT94536</p> 	<p><b>3</b> FT95381 FT95380 FT95417</p>  <p>SHORT / MEDIUM / HIGH</p>	<p><b>4</b> FT95423</p>  <p>RIGHT / LEFT</p>
<p><b>5</b> FT95419</p> 	<p><b>6</b> FT95427</p>  <p>RIGHT / LEFT</p>	<p><b>7</b> FT95412</p> 	<p><b>8</b> FT94537</p> 
<p><b>9</b> FT95382</p> 	<p><b>10</b> FT95421</p>  <p>RIGHT / LEFT</p>		

## Boxer / Jumper

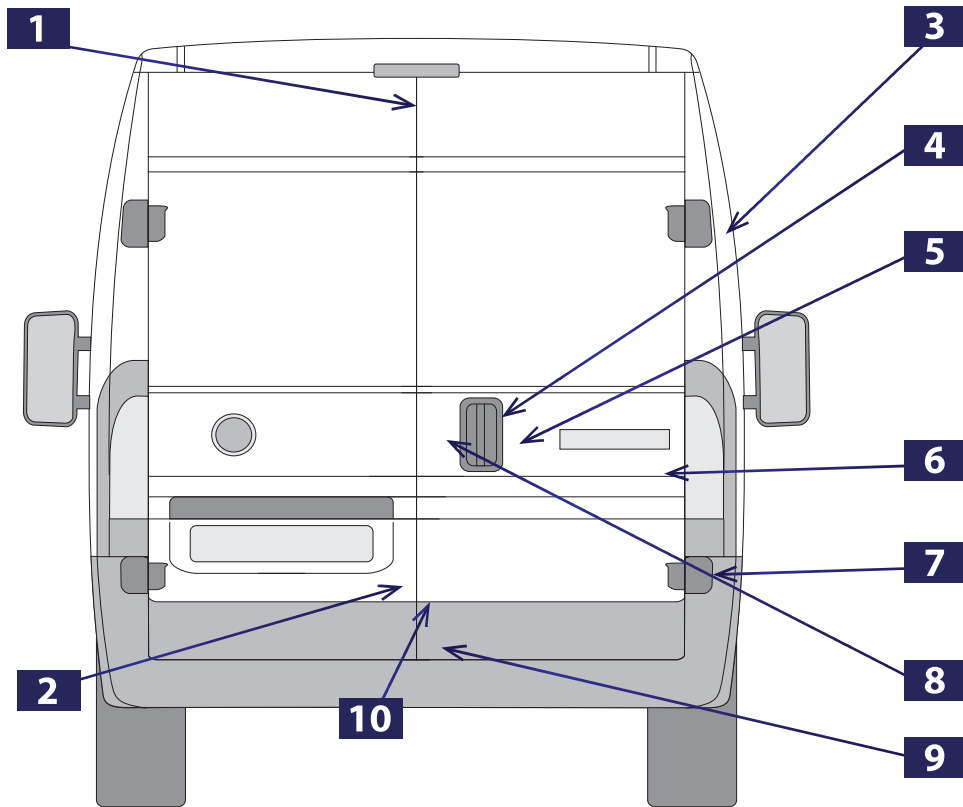

**1** FT95420



RIGHT / LEFT

**2** FT95382



**3** FT95413



**4** FT94535



**5** FT94394



**6** FT95425



**7** FT95414



**8** FT95361



**9** FT95359



**10** FT95422



RIGHT / LEFT

## Boxer / Jumper

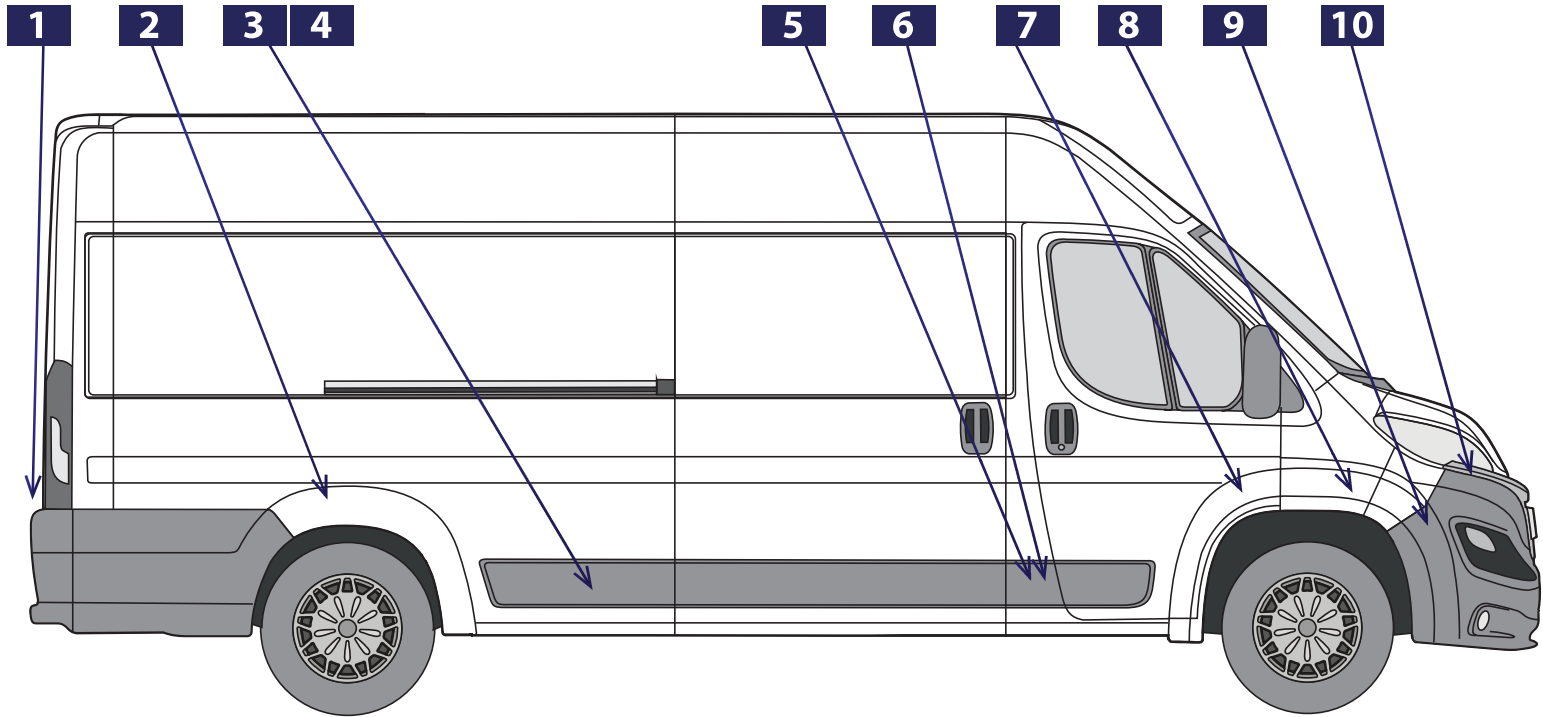

**1** FT90764 (RIGHT) //  
FT90765 (LEFT) //



**2** FT90764 (RIGHT) //  
FT90765 (LEFT) //



**3** FT90757 (RIGHT) //  
FT90758 (LEFT) //



**4** FT90770 (RIGHT) //  
FT90771 (LEFT) //



**5** FT90760 (RIGHT) //  
FT90762 (LEFT) //



**6** FT90761 (RIGHT) //  
FT90763 (LEFT) //



MAXI

**7** FT90755 (RIGHT) //  
FT90756 (LEFT) //



**8** FT90819 (RIGHT) //  
FT90818 (LEFT) //



MAXI

**9** FT90816 (RIGHT) //  
FT90815 (LEFT) //



**10** FT90632 (RIGHT) //  
FT90631 (LEFT) //



## Boxer / Jumper

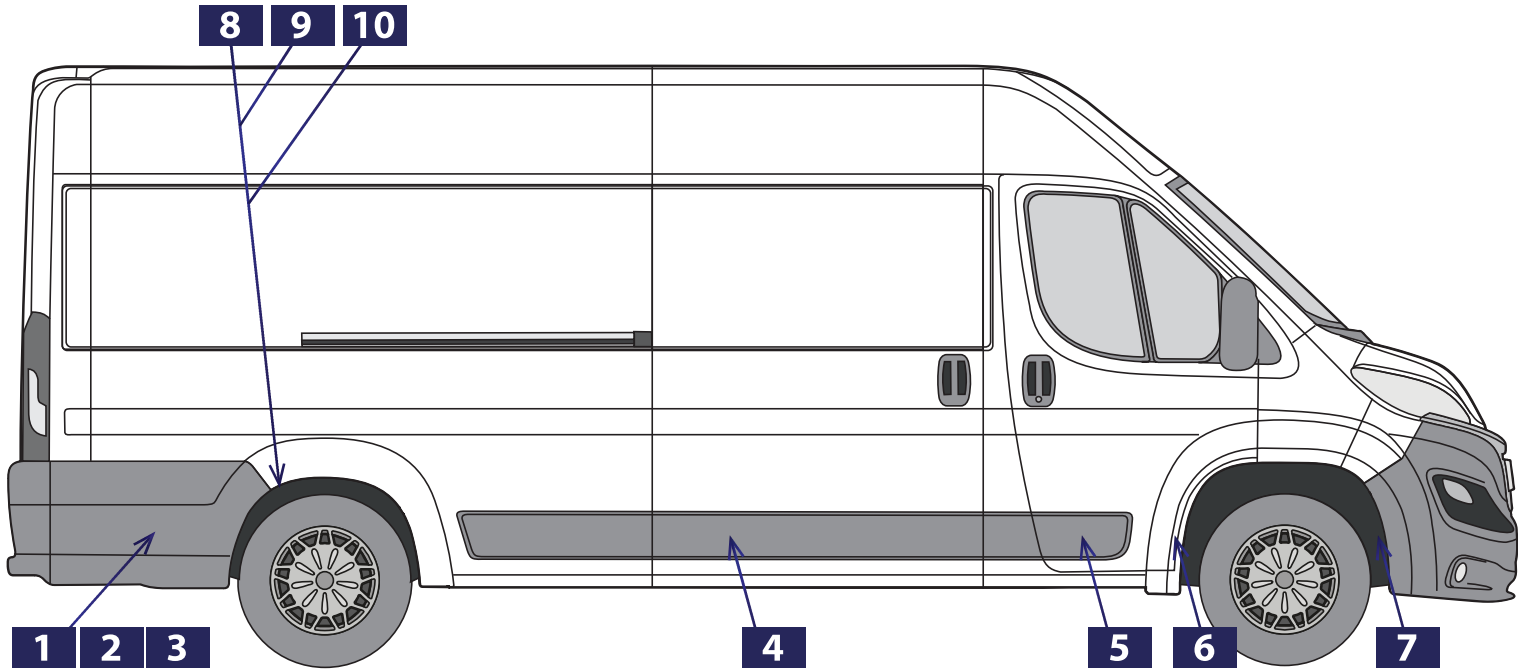

**1** FT90776 (RIGHT) //  
FT90779 (LEFT) //



**2** FT90777 (RIGHT) //  
FT90780 (LEFT) //



**3** FT90778 (RIGHT) //  
FT90781 (LEFT) //



HEAVY

**4** FT90748 (RIGHT) //  
FT90759 (LEFT) //



**5** FT90753 (RIGHT) //  
FT90754 (LEFT) //



**6** FT90772 (RIGHT) //  
FT90773 (LEFT) //



**7** FT90526 (RIGHT) //  
FT90527 (LEFT) //



**8** FT90528 (RIGHT) //  
FT90529 (LEFT) //



VAN

**9** FT90530 // //



TRUCK SINGLE

**10** FT90531 // //



TRUCK DOUBLE

## Boxer / Jumper

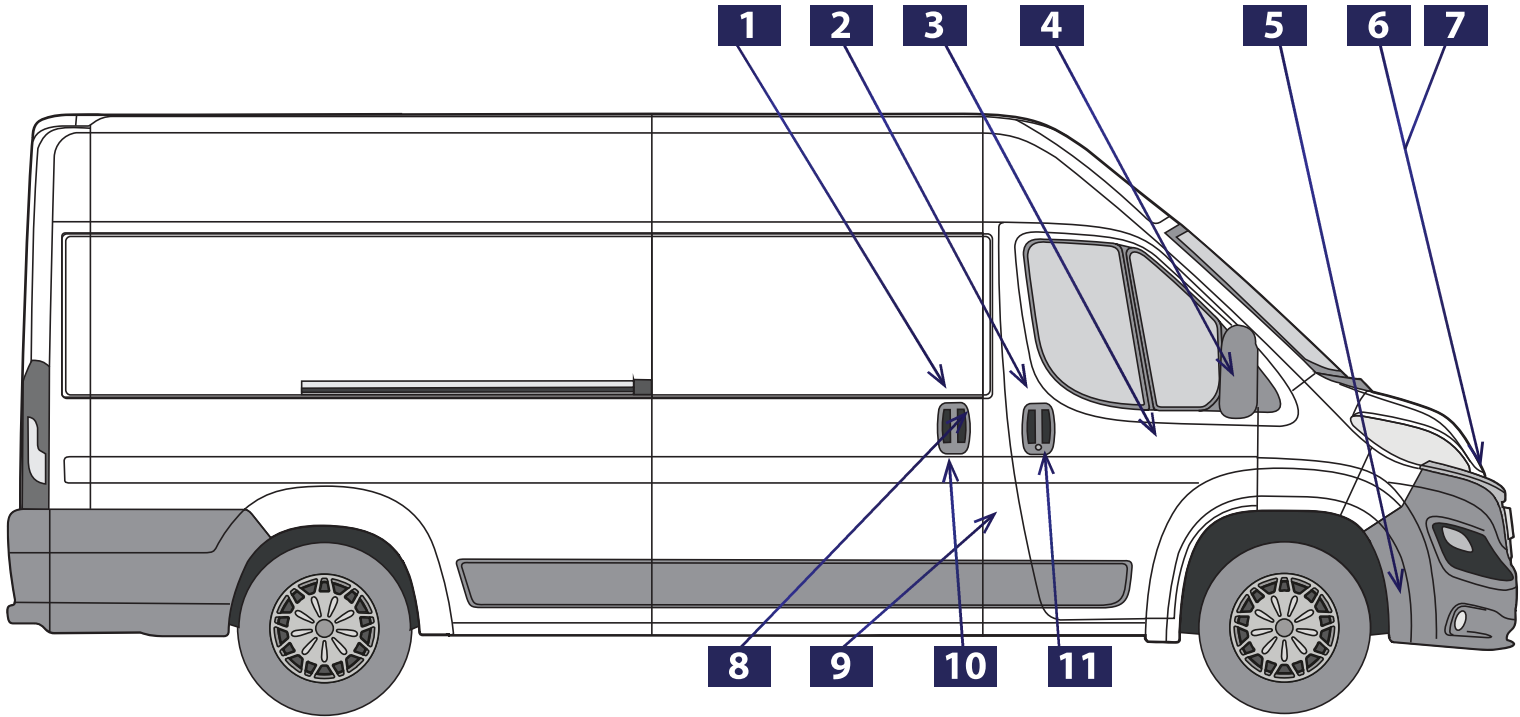

<p><b>1</b>   <b>FT94540</b> //</p>  <p>RIGHT / LEFT</p>	<p><b>2</b>   <b>FT94390</b> (RIGHT) // <b>FT94391</b> (LEFT) //</p> 	<p><b>3</b>   <b>FT94542</b> (RIGHT) // <b>FT94541</b> (LEFT) //</p> 	<p><b>4</b>   <b>FT86041</b> (RIGHT) // <b>FT86040</b> (LEFT) //</p> 
<p><b>5</b>   <b>FT90634</b> (RIGHT) // <b>FT90633</b> (LEFT) //</p> 	<p><b>6</b>   <b>FT91501</b> //</p> 	<p><b>7</b>   <b>FT91459</b> //</p> 	<p><b>8</b>   <b>FT94539</b> //</p>  <p>RIGHT</p>
<p><b>9</b>   <b>FT90785</b> //</p> 	<p><b>10</b>   <b>FT94389</b> //</p> 	<p><b>11</b>   <b>FT94157</b> //</p> 	



## Boxer / Jumper

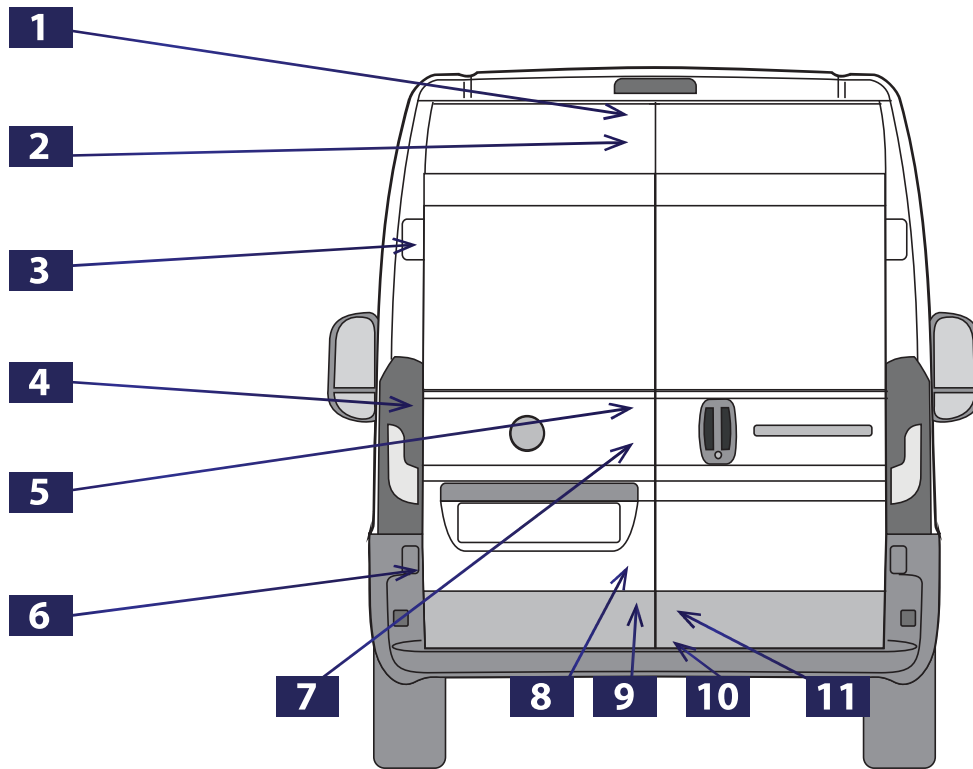

<p><b>1</b> FT95423</p>  <p>RIGHT / LEFT</p>	<p><b>2</b> FT95381 FT95380 FT95417</p>  <p>SHORT / MEDIUM / HIGH</p>	<p><b>3</b> FT95411</p> 	<p><b>4</b> FT95427</p> 
<p><b>5</b> FT94536</p> 	<p><b>6</b> FT95412</p> 	<p><b>7</b> FT94537</p> 	<p><b>8</b> FT95382</p> 
<p><b>9</b> FT95421</p>  <p>RIGHT / LEFT</p>	<p><b>10</b> FT95359</p> 	<p><b>11</b> FT95422</p> 	



## Boxer / Jumper

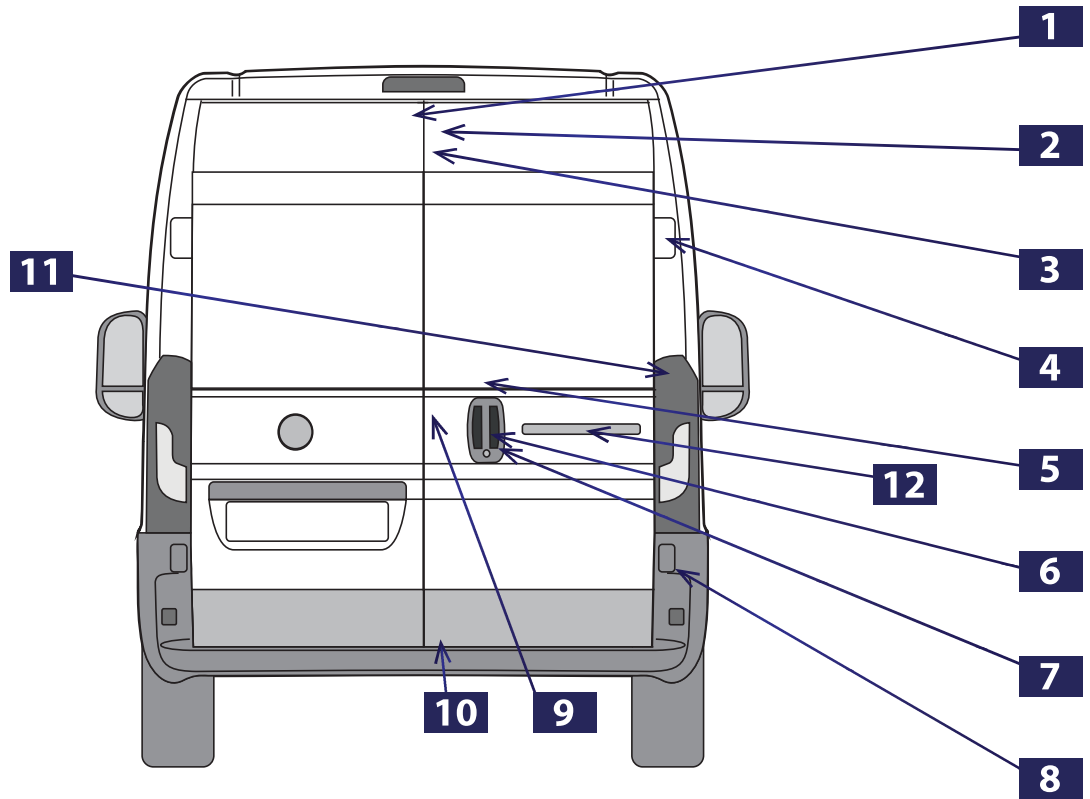

<p><b>1</b>   <b>FT95419</b> //</p> 	<p><b>2</b>   <b>FT95420</b> //</p>  <p>RIGHT / LEFT</p>	<p><b>3</b>   <b>FT95384</b> // <b>FT95418</b> // <b>FT95383</b> //</p>  <p>SHORT / MEDIUM / HIGH</p>	<p><b>4</b>   <b>FT95413</b> //</p> 
<p><b>5</b>   <b>FT94535</b> //</p> 	<p><b>6</b>   <b>FT94394</b> //</p> 	<p><b>7</b>   <b>FT95425</b> //</p> 	<p><b>8</b>   <b>FT95414</b> //</p> 
<p><b>9</b>   <b>FT95361</b> //</p> 	<p><b>10</b>   <b>FT91458</b> //</p> 	<p><b>11</b>   <b>FT95426</b> //</p> 	<p><b>12</b>   <b>FT95590</b> //</p> 

## Boxer / Jumper

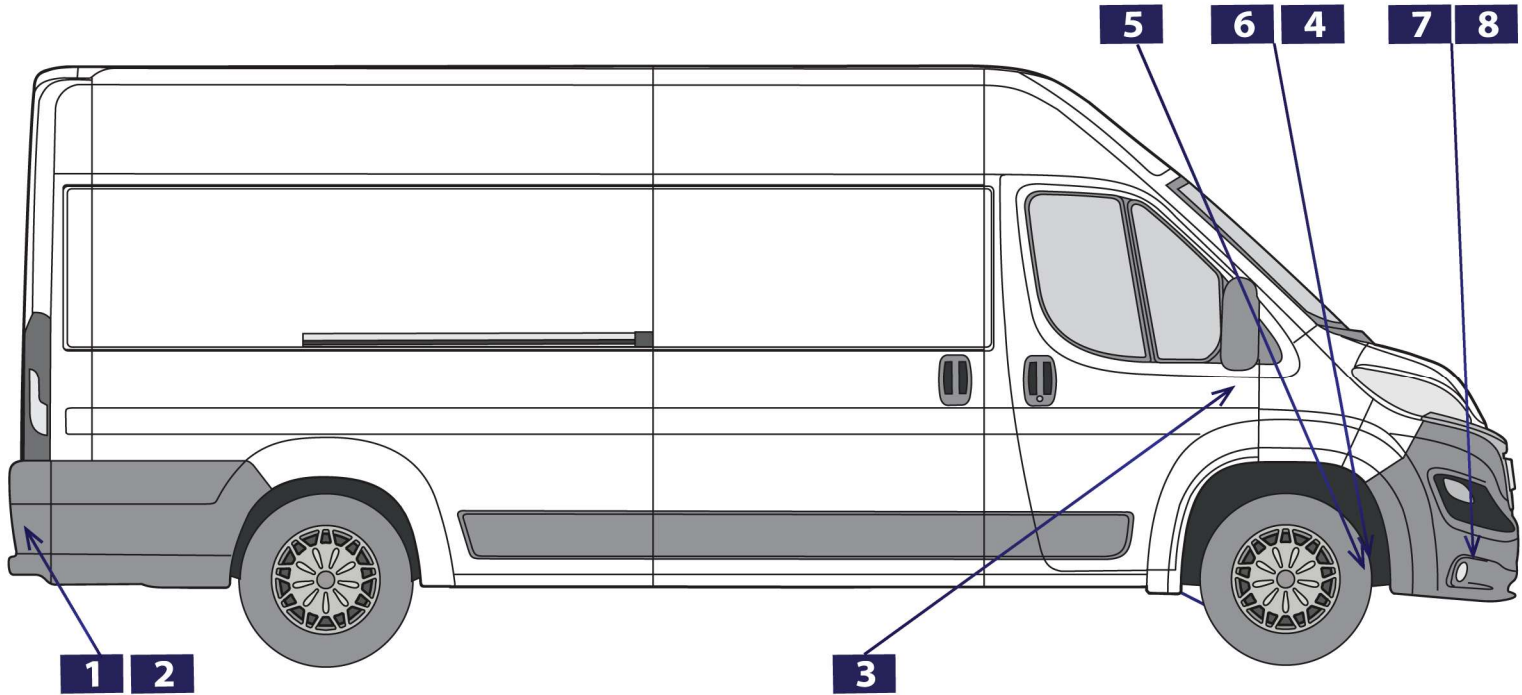

<p><b>1</b> FT91444 (RIGHT) // FT91443 (LEFT) //</p> 	<p><b>2</b> FT91446 (RIGHT) // FT91445 (LEFT) //</p> 	<p><b>3</b> FT95379 //</p>  <p>RIGHT / LEFT</p>	<p><b>4</b> FT99007 //</p>  <p>LEFT</p>
<p><b>5</b> FT99006 //</p>  <p>MIDDLE</p>	<p><b>6</b> FT99008 //</p>  <p>RIGHT</p>	<p><b>7</b> FT91451 (RIGHT) // FT91452 (LEFT) //</p>  <p>LIGHT</p> <p>SENZA FORI MODANATURA</p>	<p><b>8</b> FT91455 (RIGHT) // FT91456 (LEFT) //</p>  <p>HEAVY</p> <p>CON FORI MODANATURA</p>

## Boxer / Jumper

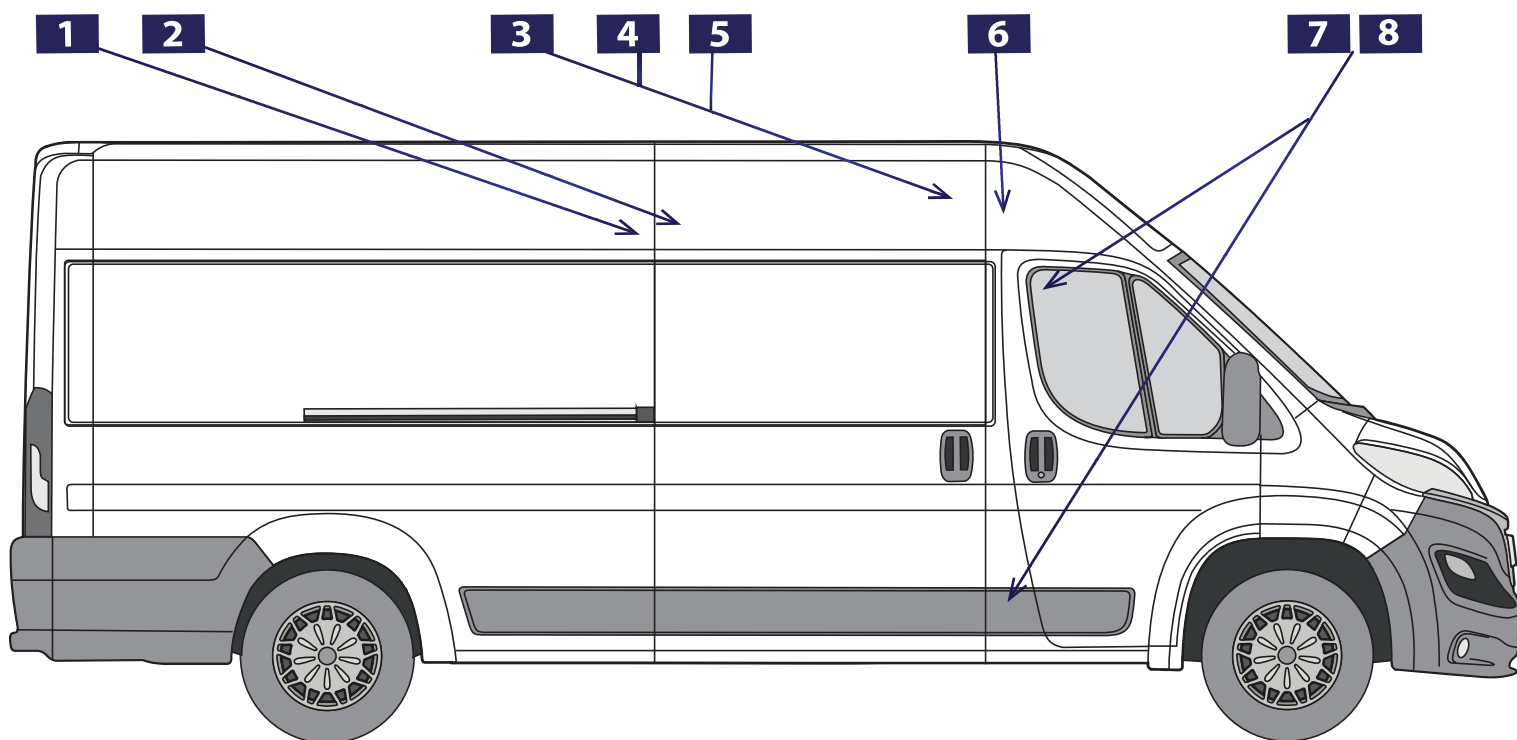

**1** FT95376



**2** FT95340



**3** FT95371



**4** FT95387



**5** FT95350



**6** FT95361



**7** FT95416



**8** FT95415



## Boxer / Jumper

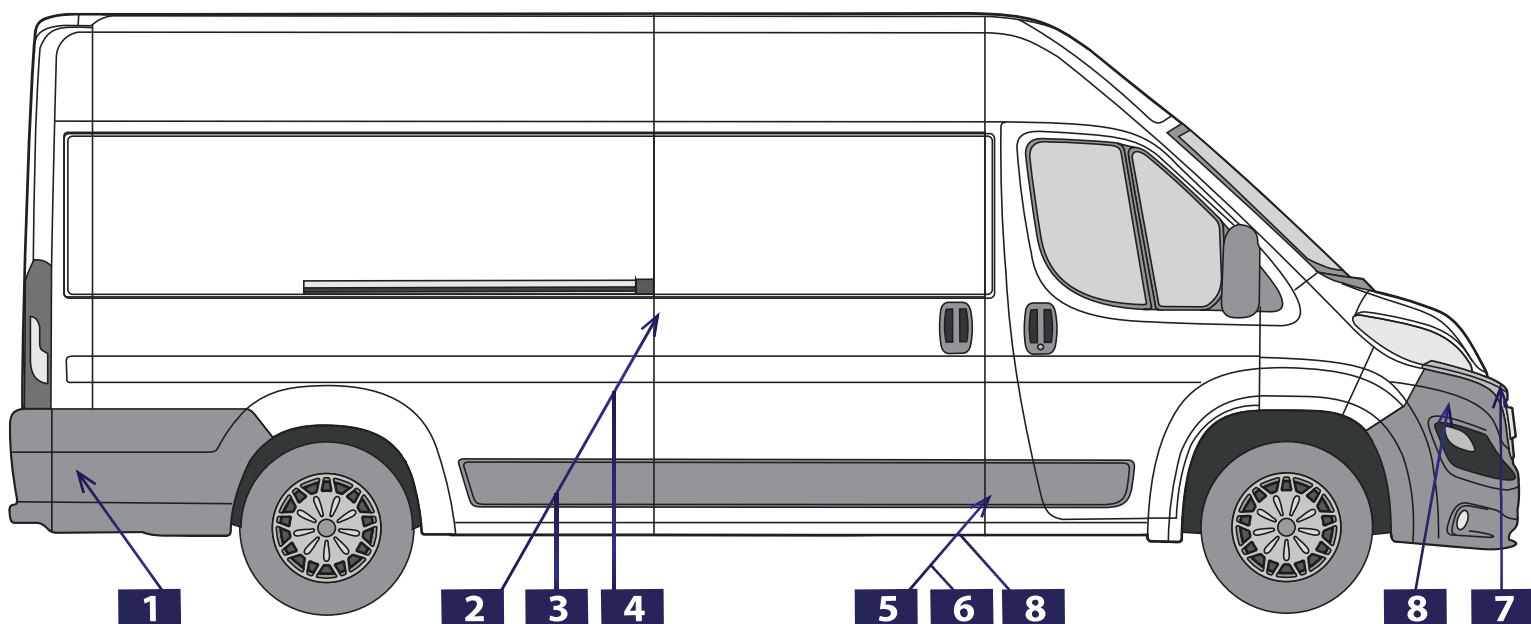

<p><b>1</b> FT95359</p>  <p>LOW</p>	<p><b>2</b> FT95373</p>  <p>SET</p>	<p><b>3</b> FT95388</p> 	<p><b>4</b> FT95352</p> 
<p><b>5</b> FT95351</p> 	<p><b>6</b> FT95389</p> 	<p><b>7</b> FT94150</p> 	<p><b>8</b> FT995372</p>  <p>SET</p>

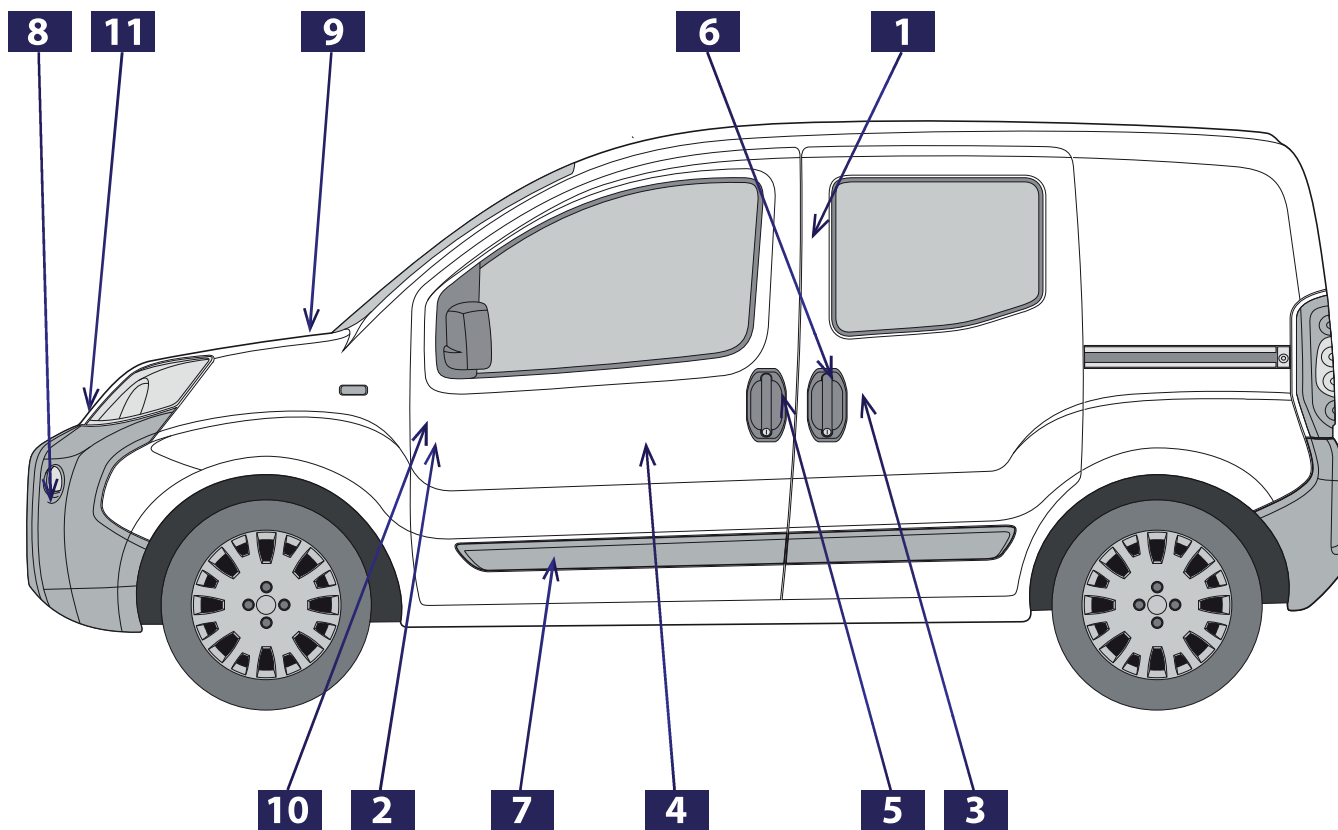

<b>1</b>   <b>FT95405</b>  	<b>2</b>   <b>FT95406</b>  	<b>3</b>   <b>FT94575</b>  	<b>4</b>   <b>FT94552</b>   RIGHT / LEFT
<b>5</b>   <b>FT94554</b>   LEFT	<b>6</b>   <b>FT94576</b>   RIGHT SLIDING DOOR	<b>7</b>   <b>FT90805</b> (RIGHT)  <b>FT90804</b> (LEFT)  	<b>8</b>   <b>FT91640</b> (RIGHT)  <b>FT91641</b> (LEFT)  
<b>9</b>   <b>FT94096</b> (RIGHT)  <b>FT94095</b> (LEFT)  	<b>10</b>   <b>FT95378</b>  	<b>11</b>   <b>FT94168</b>  	



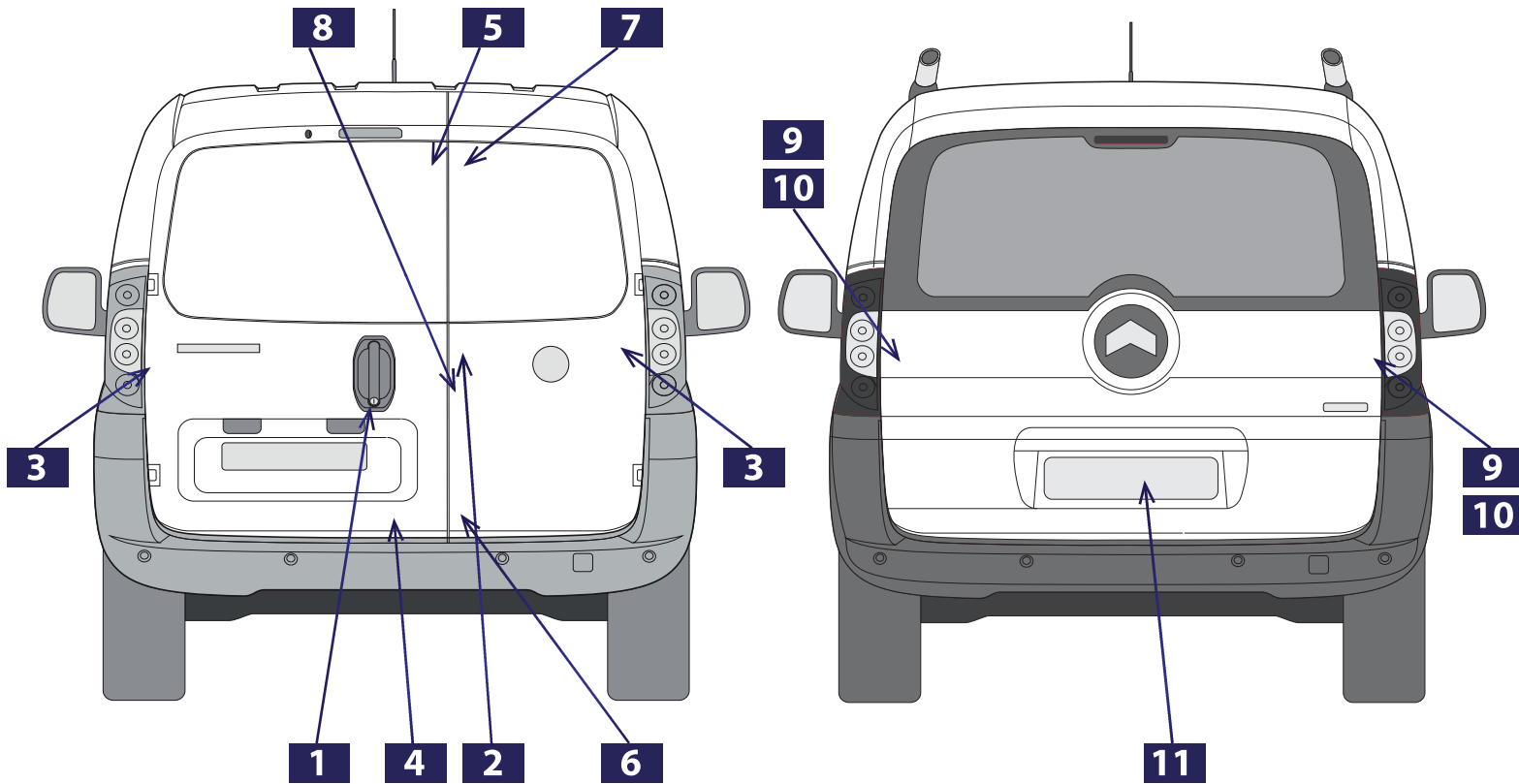

1	FT94555	2	FT94537	3	FT95399	4	FT95592
5	FT95531	6	FT95460	7	FT95532	8	FT95361
9	FT95465	10	FT95466	11	FT95462		

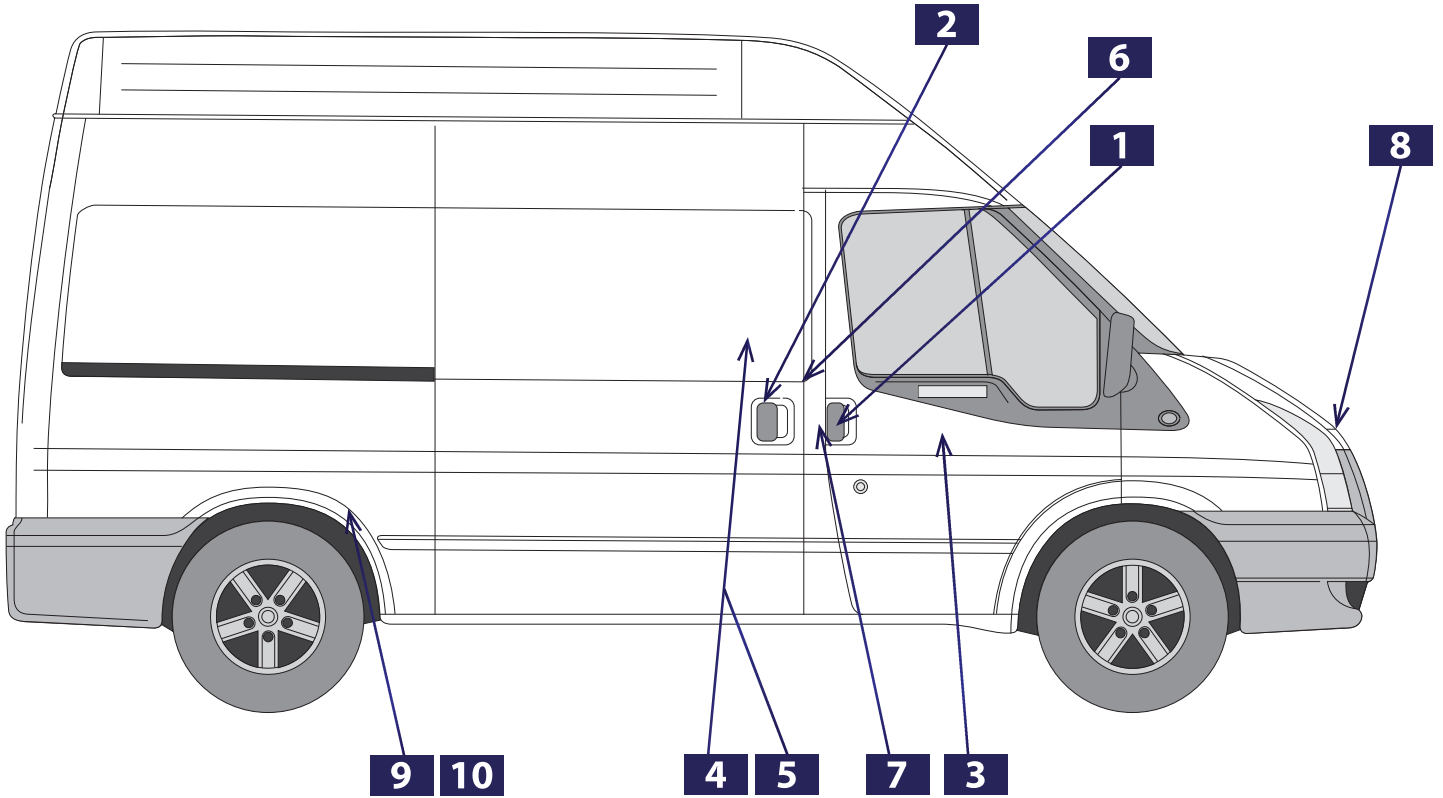

<p><b>1</b> FT94565 (RIGHT)  FT94566 (LEFT) </p> 	<p><b>2</b> FT94574 </p>  <p style="text-align: center;">SLIDING DOOR</p>	<p><b>3</b> FT94562 (RIGHT)  FT94563 (LEFT) </p> 	<p><b>4</b> FT94561 </p>  <p style="text-align: right;">LOW</p>
<p><b>5</b> FT94560 </p>  <p style="text-align: right;">HIGH</p>	<p><b>6</b> FT95437 </p> 	<p><b>7</b> FT95438 </p> 	<p><b>8</b> FT95439 </p> 
<p><b>9</b> FT90530 </p>  <p style="text-align: right;">TRUCK SINGLE</p>	<p><b>10</b> FT90531 </p>  <p style="text-align: right;">TRUCK DOUBLE</p>		



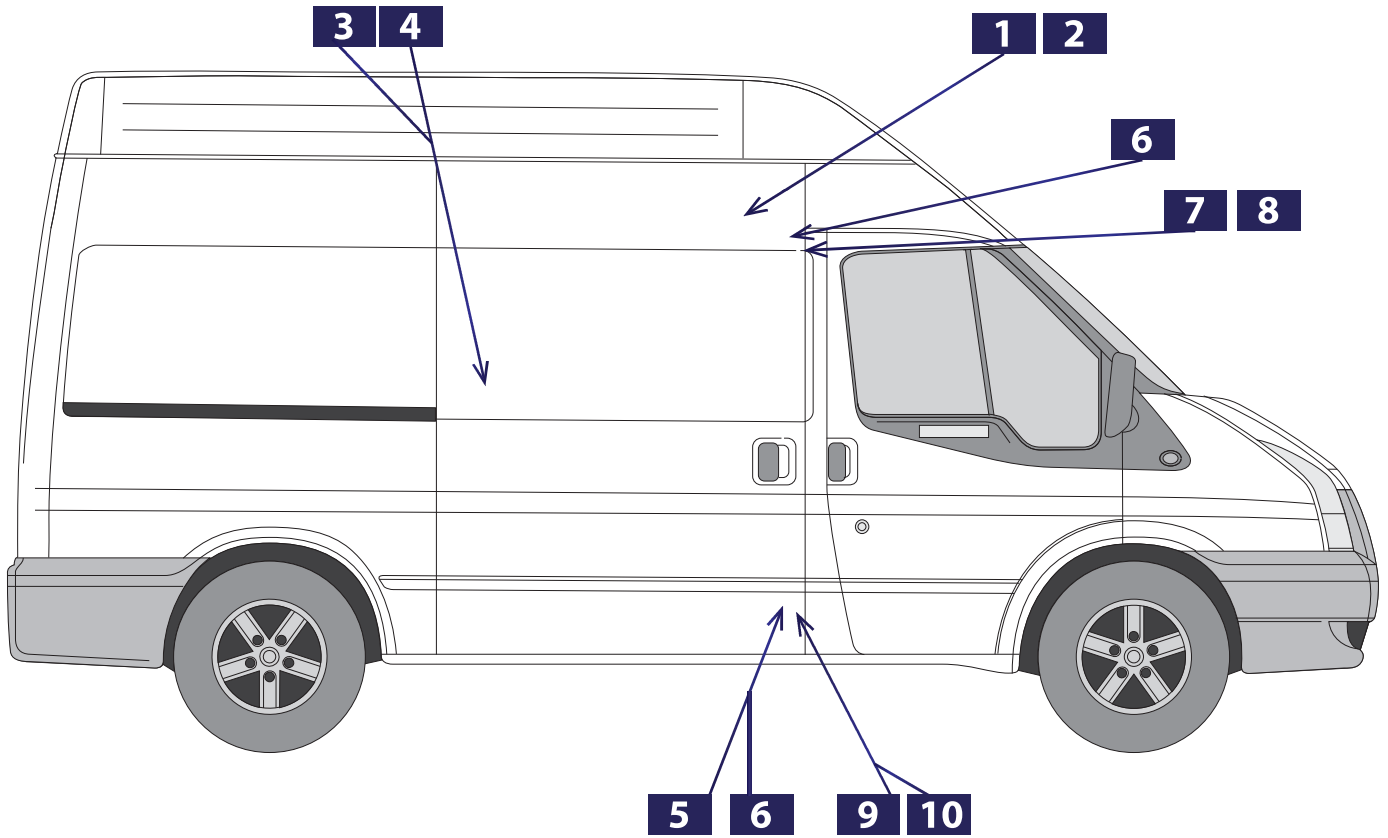

<b>1</b>   <b>FT95558</b> 	<b>2</b>   <b>FT95559</b> 	<b>3</b>   <b>FT95561</b> 	<b>4</b>   <b>FT95560</b> 
<b>5</b>   <b>FT95562</b> 	<b>6</b>   <b>FT95563</b> 	<b>7</b>   <b>FT95451</b> 	<b>8</b>   <b>FT95452</b> 
<b>9</b>   <b>FT95449</b> 	<b>10</b>   <b>FT95450</b> 		

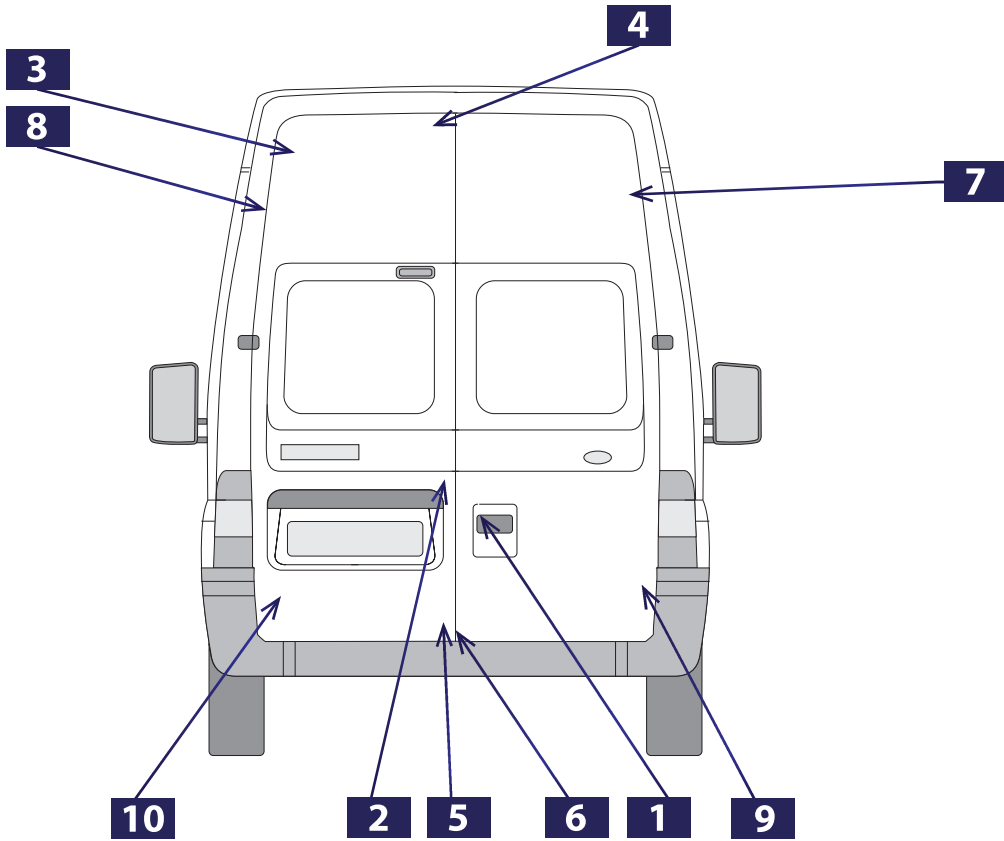

<b>1</b>   <b>FT94564</b>  	<b>2</b>   <b>FT94559</b>  	<b>3</b>   <b>FT95444</b>  	<b>4</b>   <b>FT95447</b>  
<b>5</b>   <b>FT95445</b>  	<b>6</b>   <b>FT95446</b>  	<b>7</b>   <b>FT95440</b>  	<b>8</b>   <b>FT95441</b>  
<b>9</b>   <b>FT95442</b>  	<b>10</b>   <b>FT95443</b>  		

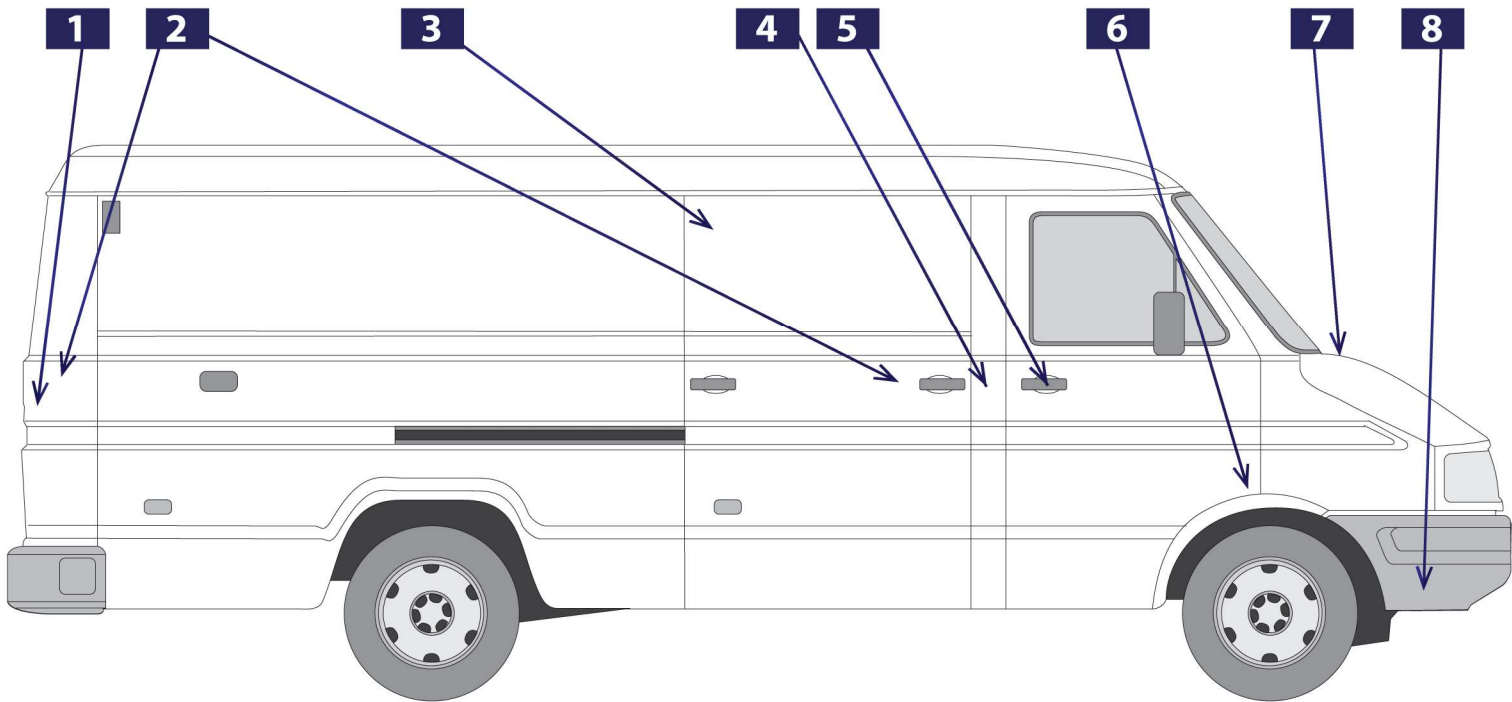

**1** FT95160



**2** FT94480



**3** FT95273



**4** FT95156 (RIGHT) / FT95157 (LEFT)



**5** FT95226 (RIGHT) / FT95227 (LEFT)



**6** FT90715 (RIGHT) / FT90714 (LEFT)



**7** FT90695



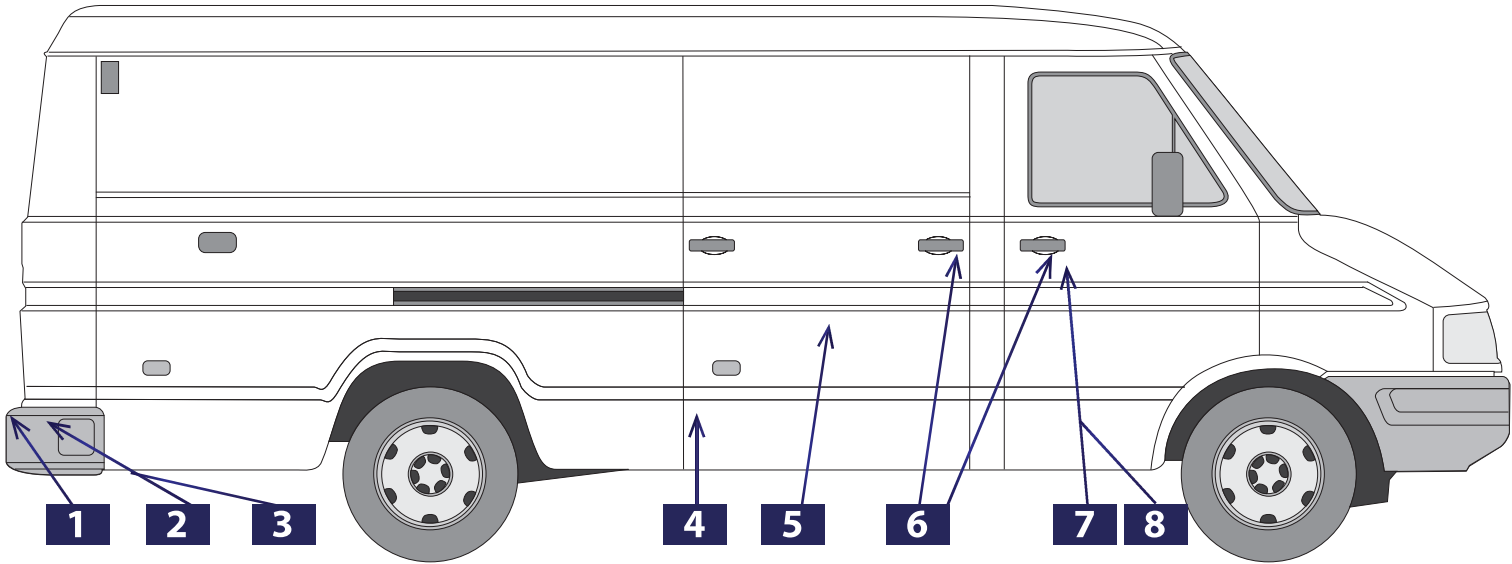

**1** FT91393



**2** FT91392



**3** FT91391



**4** FT95266



**5** FT95267



**6** FT94120



**7** FT94301



**8** FT94300



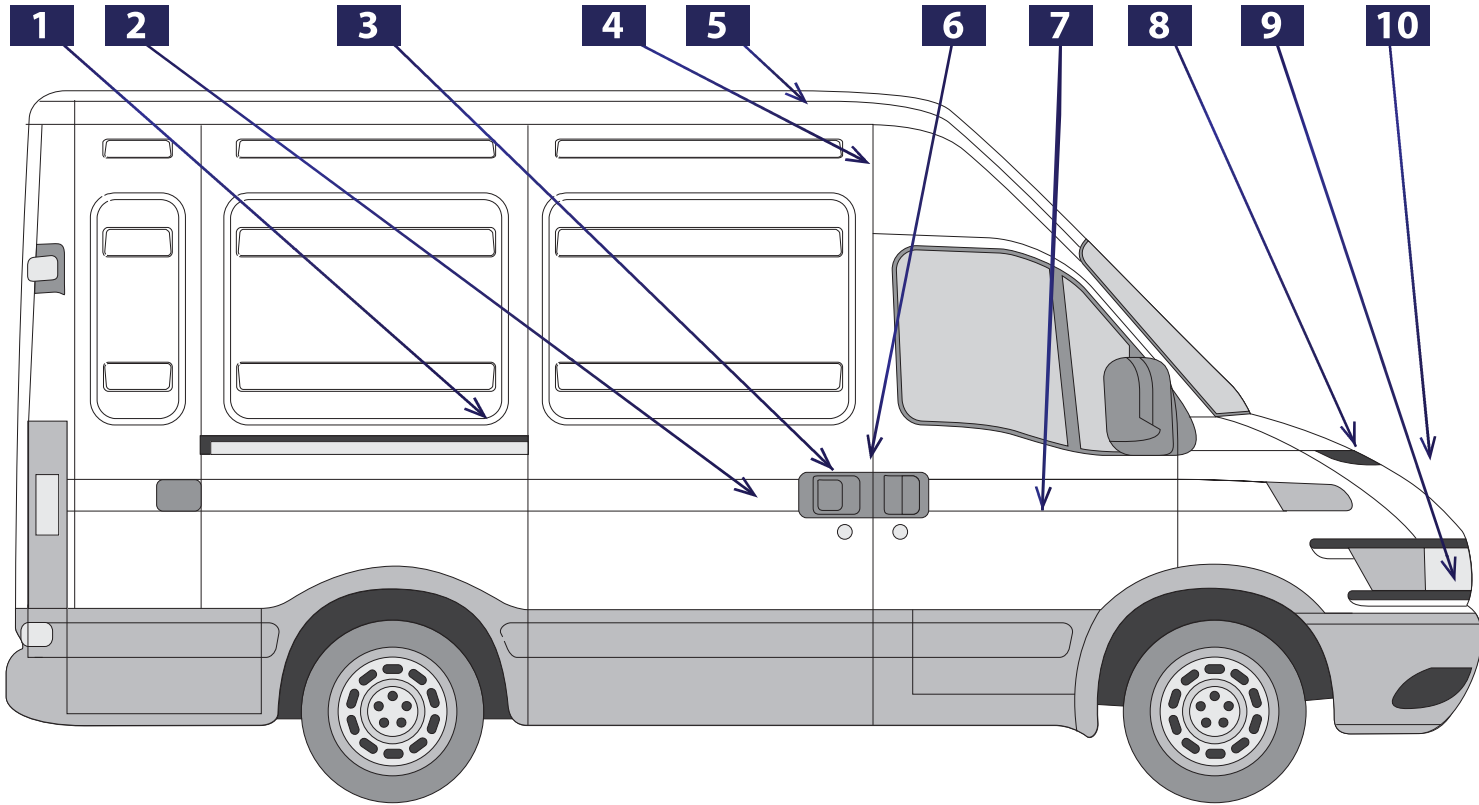

**1** FT95364



**2** FT94530



**3** FT94546  
FT94516



WITH ACTUATOR /  
WITHOUT ACTUATOR

**4** FT95374



**5** FT95336



**6** FT95375



RIGHT / LEFT

**7** FT94532 (RIGHT)  
FT94531 (LEFT)



**8** FT90728 (RIGHT)  
FT90727 (LEFT)



**9** FT91625



**10** FT90110



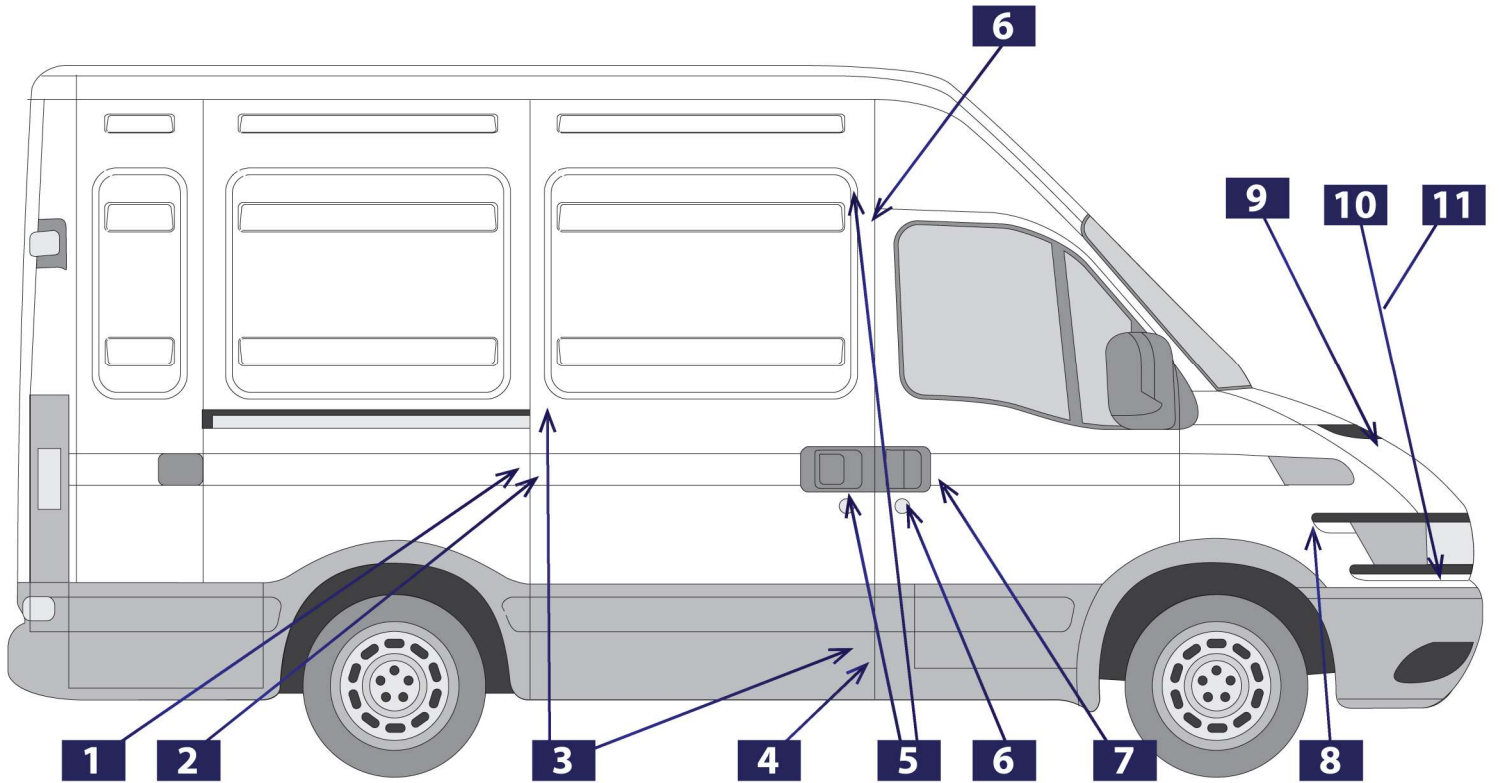

<p><b>1</b> FT95366</p> 	<p><b>2</b> FT95363</p> 	<p><b>3</b> FT95506</p> 	<p><b>4</b> FT95511</p> 
<p><b>5</b> FT95425</p> 	<p><b>6</b> FT95335</p> 	<p><b>7</b> FT94514 (RIGHT) FT94515 (LEFT)</p> 	



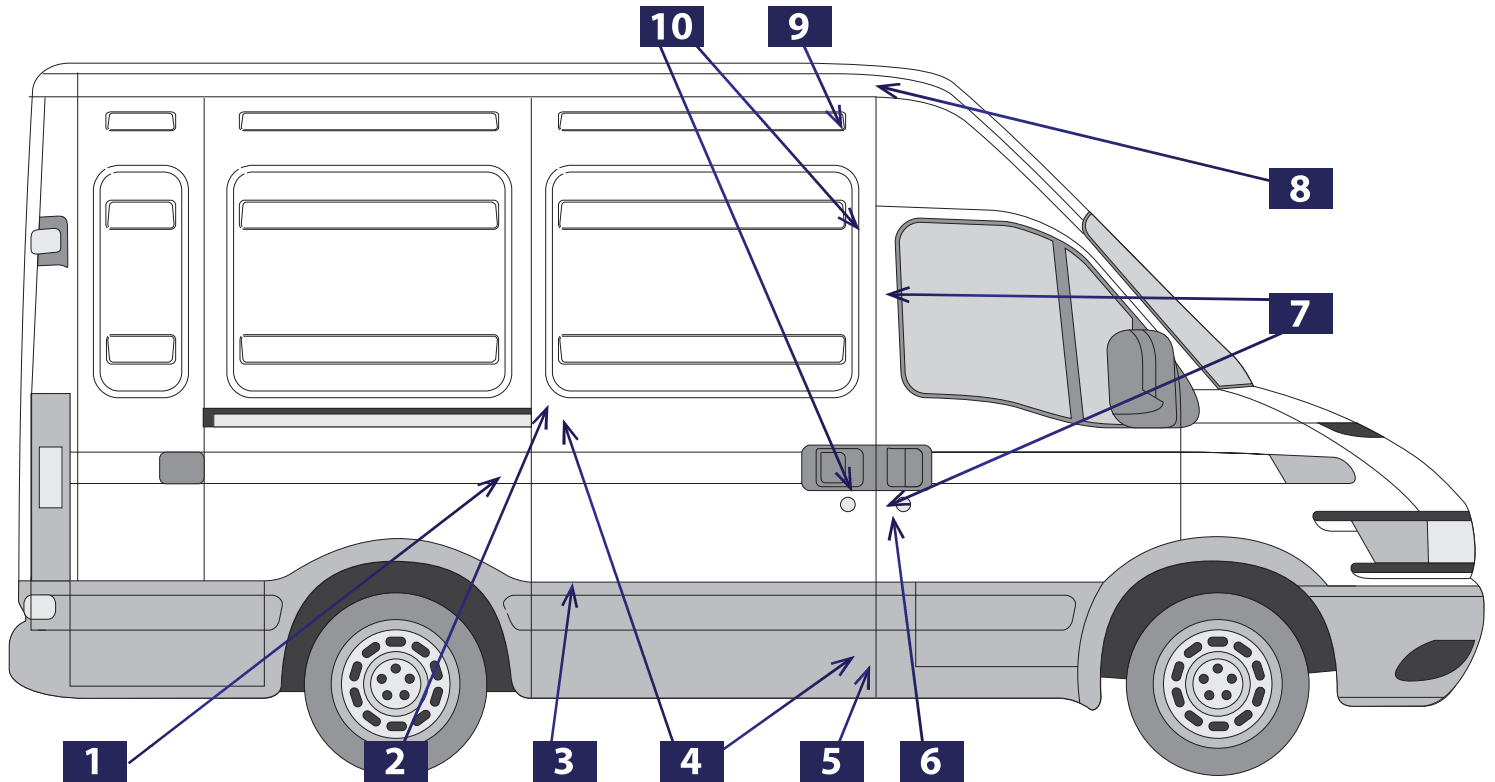

**1** | FT95366

**2** | FT95364

RIGHT / LEFT

**3** | FT95363

**4** | FT95506

**5** | FT95511

**6** | FT95375

**7** | FT95335

**8** | FT95336

**9** | FT95374

**10** | FT95425



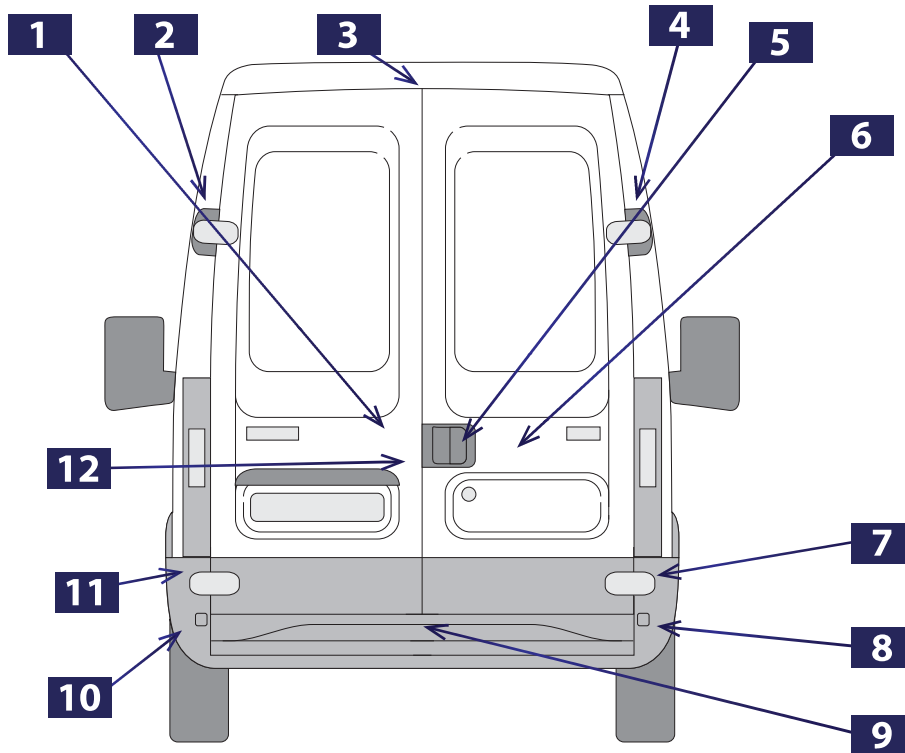

1	FT95363	2	FT94145	3	FT95362	4	FT94145
5	FT94529	6	FT94534	7	FT94146	8	FT91388
9	FT95299	10	FT91387	11	FT94146	12	FT95424

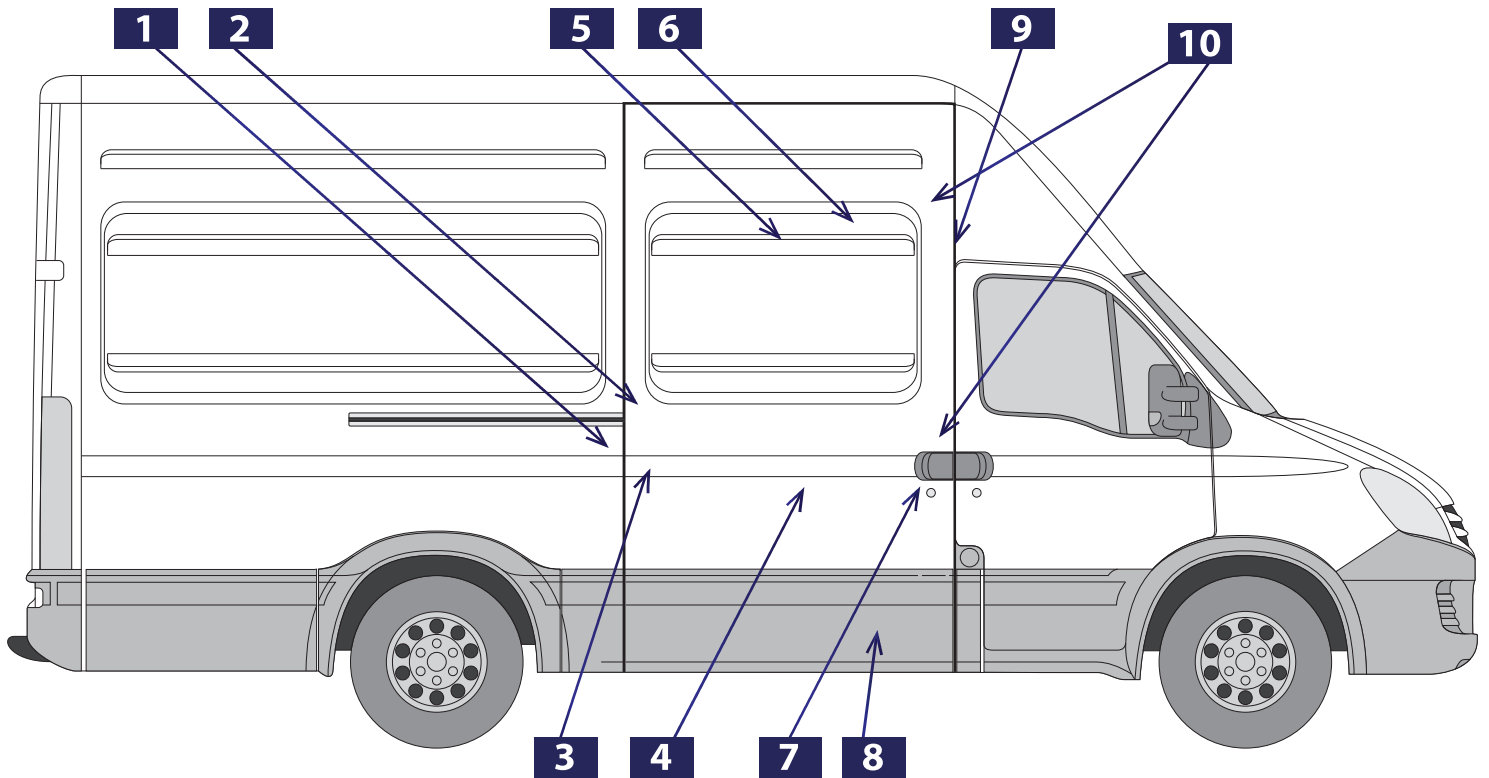

**1** FT95366

**2** FT95369

**3** FT95363

**4** FT94530

**5** FT95368

**6** FT95374

**7** FT94546  
FT94516

WITH ACTUATOR /  
WITHOUT ACTUATOR

**8** FT95370

**9** FT95375

RIGHT / LEFT

**10** FT95425

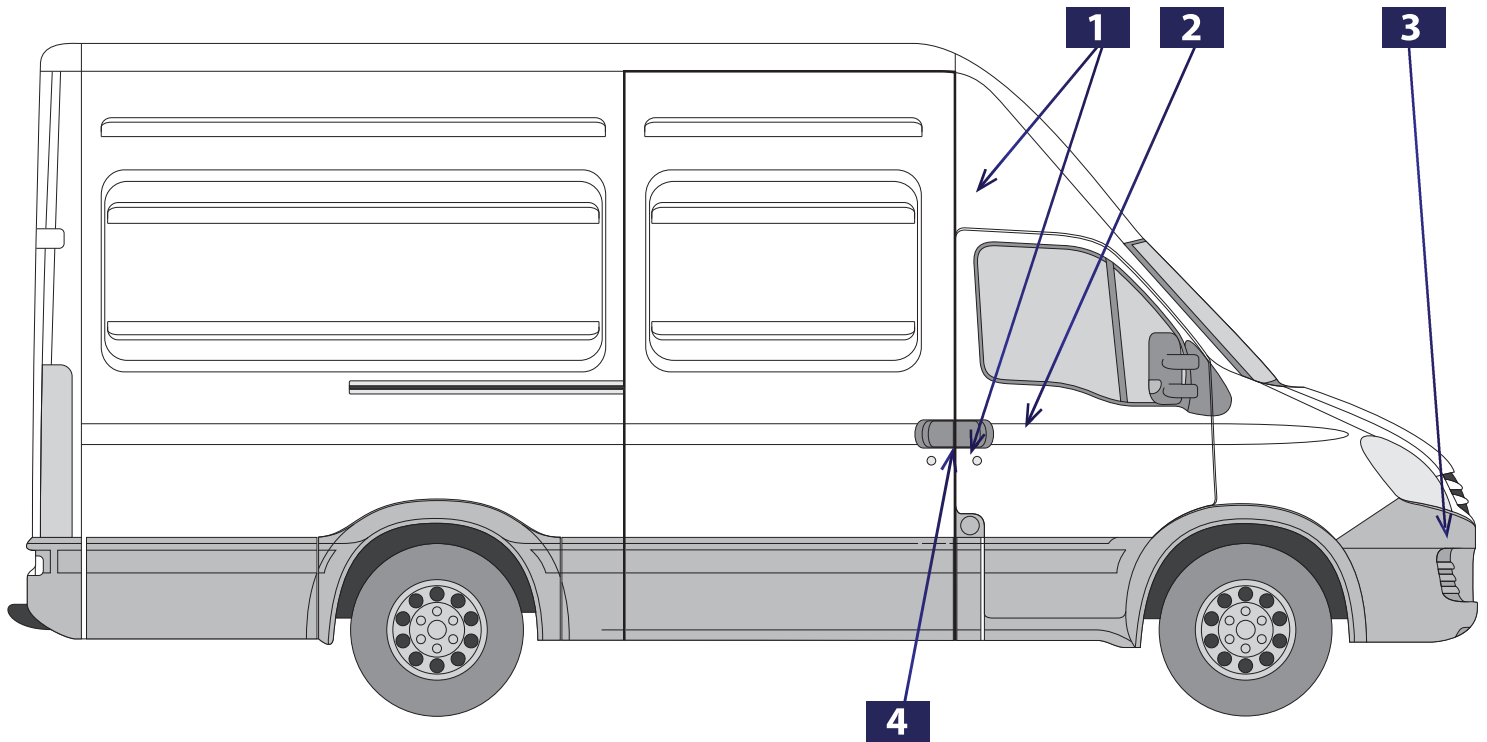

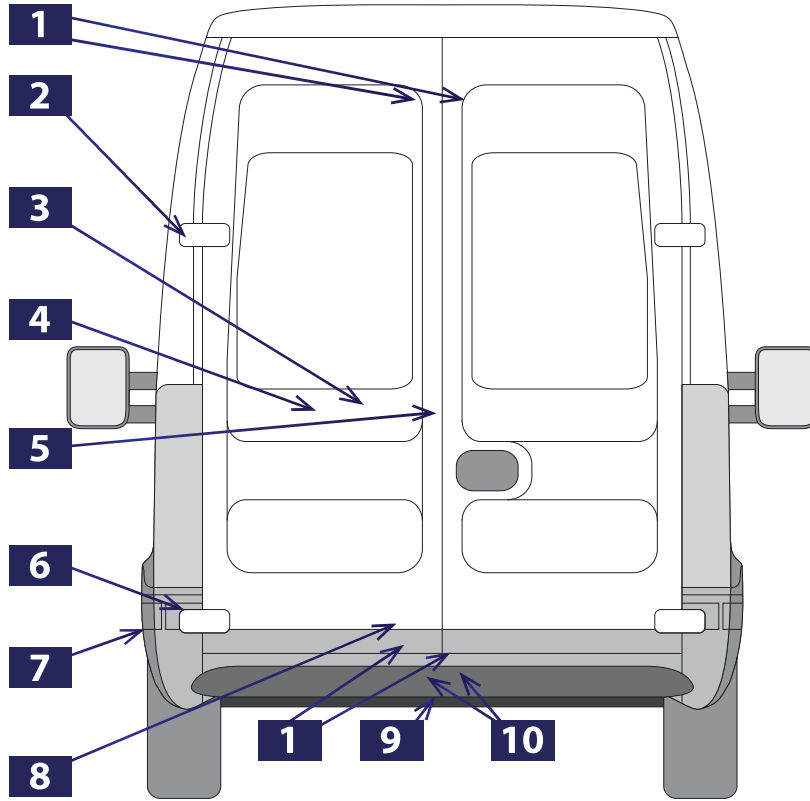

<p><b>1</b> FT95397</p> <p>RIGHT / LEFT</p>	<p><b>2</b> FT94145</p>	<p><b>3</b> FT95394</p>	<p><b>4</b> FT94544</p>
<p><b>5</b> FT95375</p>	<p><b>6</b> FT94146</p>	<p><b>7</b> FT91384</p> <p>LEFT</p>	<p><b>8</b> FT95390</p>
<p><b>9</b> FT95396</p>	<p><b>10</b> FT95393</p> <p>RIGHT / LEFT</p>		

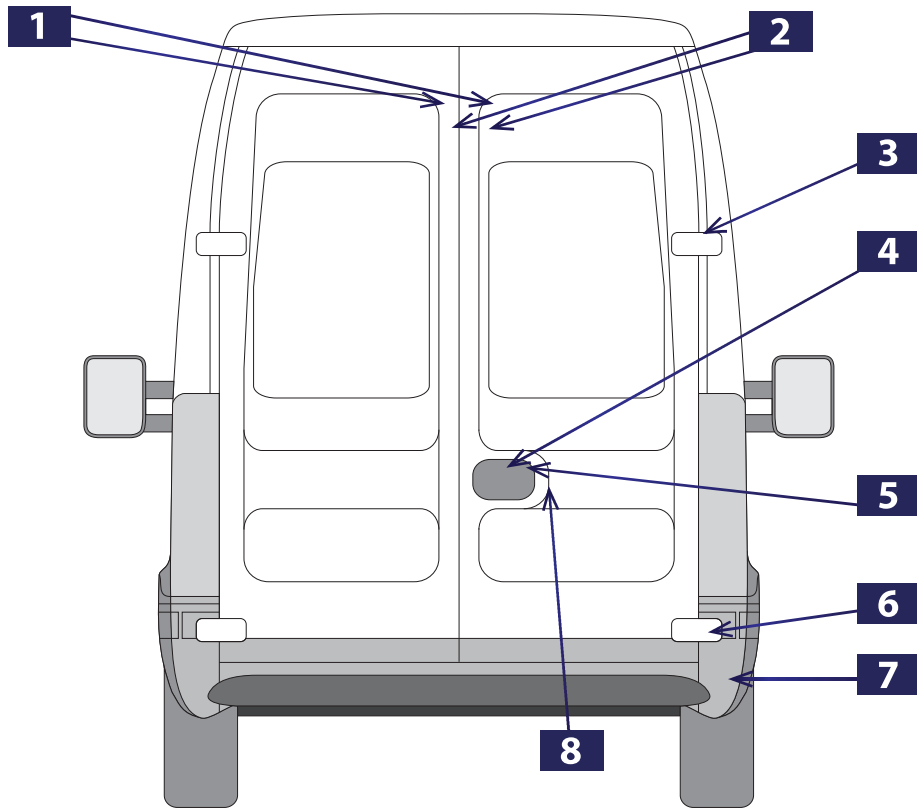

**1** FT95391 (RIGHT)   
 FT95392 (LEFT)



**2** FT95395



RIGHT / LEFT

**3** FT94145



**4** FT95363



**5** FT94543



**6** FT94146



**7** FT91383



RIGHT

**8** FT94534



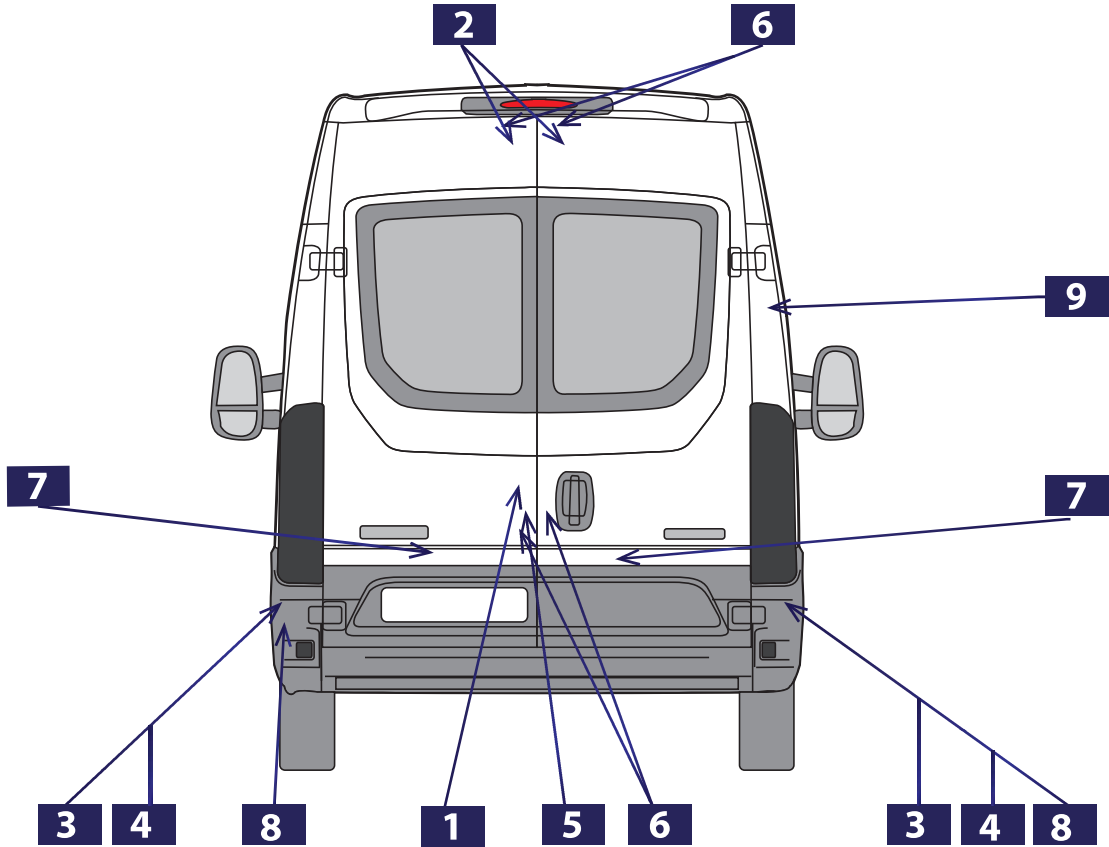

<p><b>1</b> FT94544</p>	<p><b>2</b> FT95391 (RIGHT) FT95392 (LEFT)</p>	<p><b>3</b> FT90530</p> <p>TRUCK SINGLE</p>	<p><b>4</b> FT90531</p> <p>TRUCK DOUBLE</p>
<p><b>5</b> FT95394</p>	<p><b>6</b> FT95397</p>	<p><b>7</b> FT95393</p>	<p><b>8</b> FT90796</p> <p>TRUCK</p>
<p><b>9</b> FT94581</p> <p>SLIDE</p>			

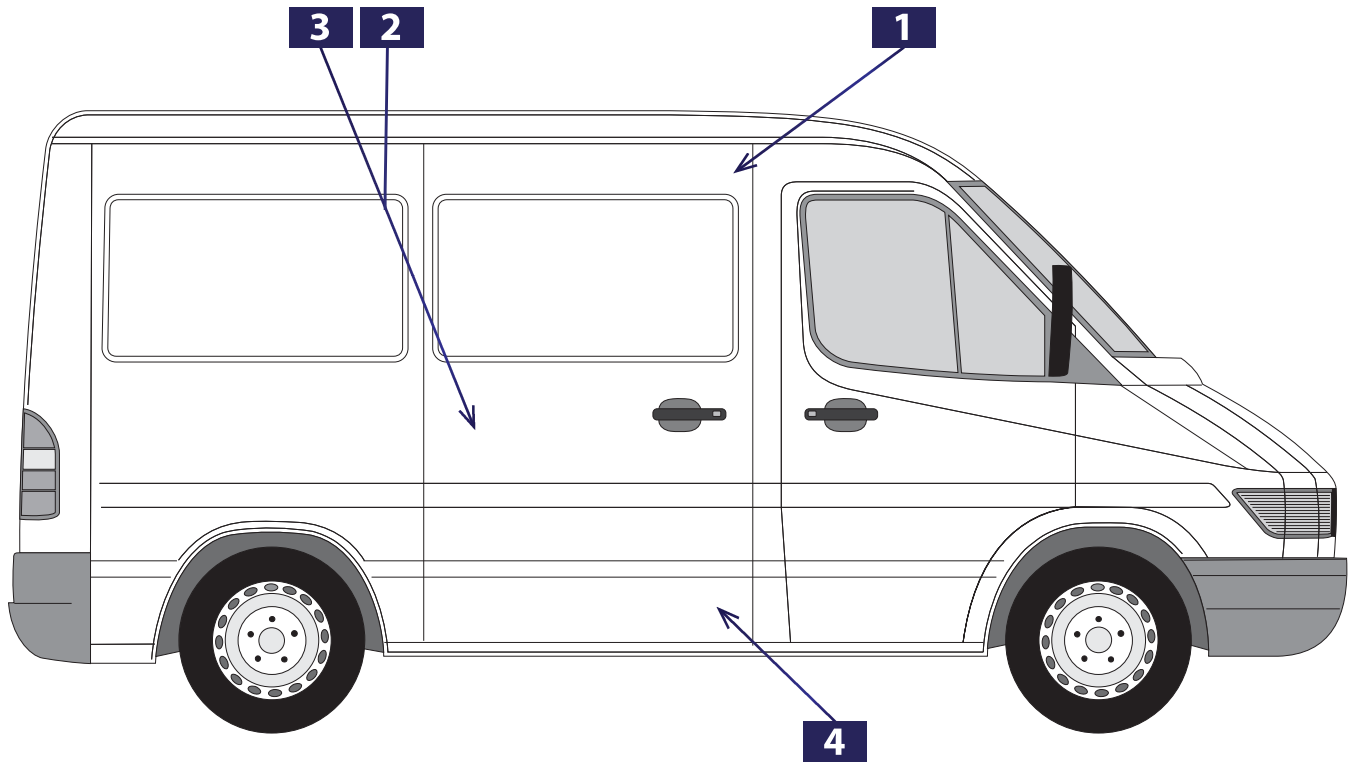

<p><b>1</b> FT95555</p>	<p><b>2</b> FT95529</p>	<p><b>3</b> FT95556</p>	<p><b>4</b> FT95557</p>
<p><b>5</b> FT95502</p> <p>1+3+4</p>			



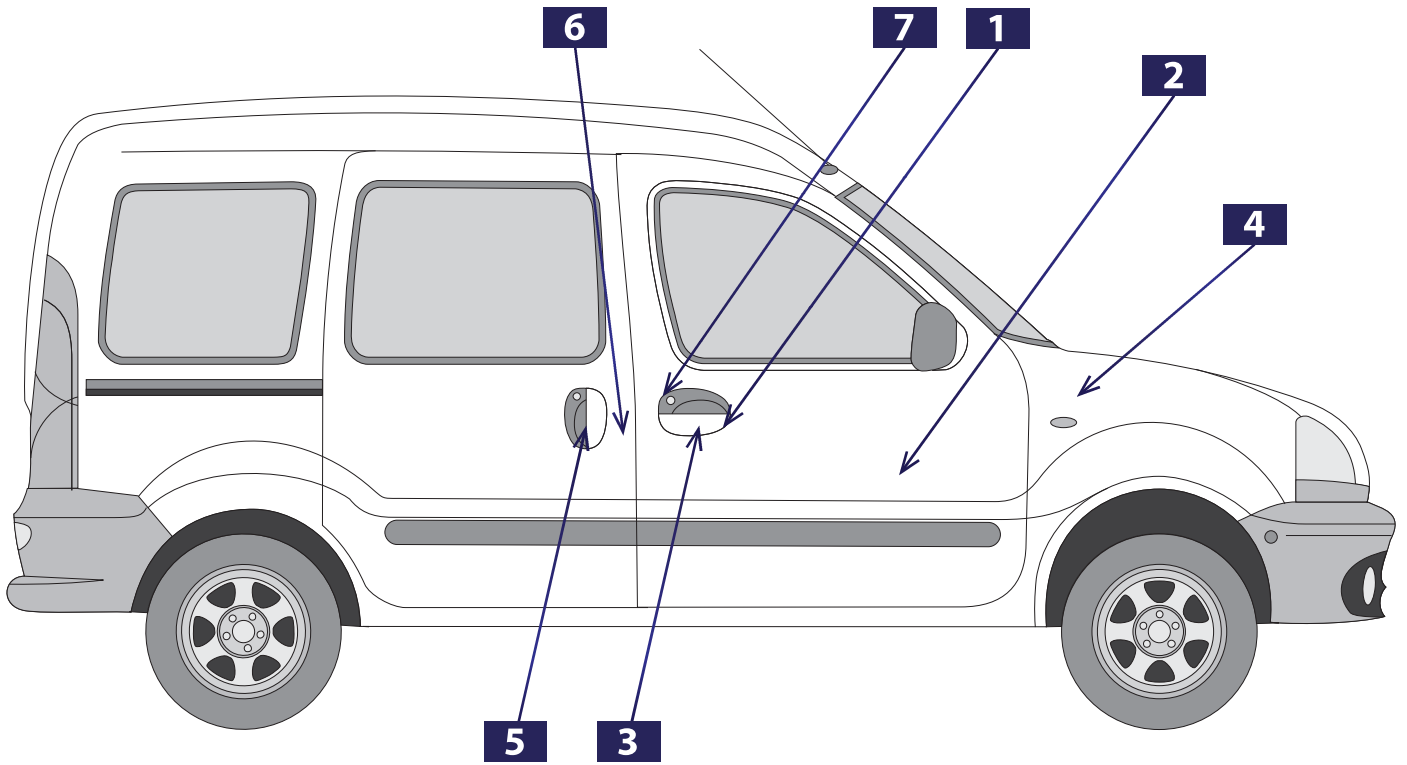

**1** FT94568 (RIGHT) // //  
 FT94569 (LEFT) // //



RIGHT / LEFT

**2** FT94558 (RIGHT) // //  
 FT94557 (LEFT) // //



**3** FT94153 // //



**4** FT95473 (RIGHT) // //  
 FT95472 (LEFT) // //



**5** FT94572 // //



**6** FT94570 // //



**7** FT94162 // //



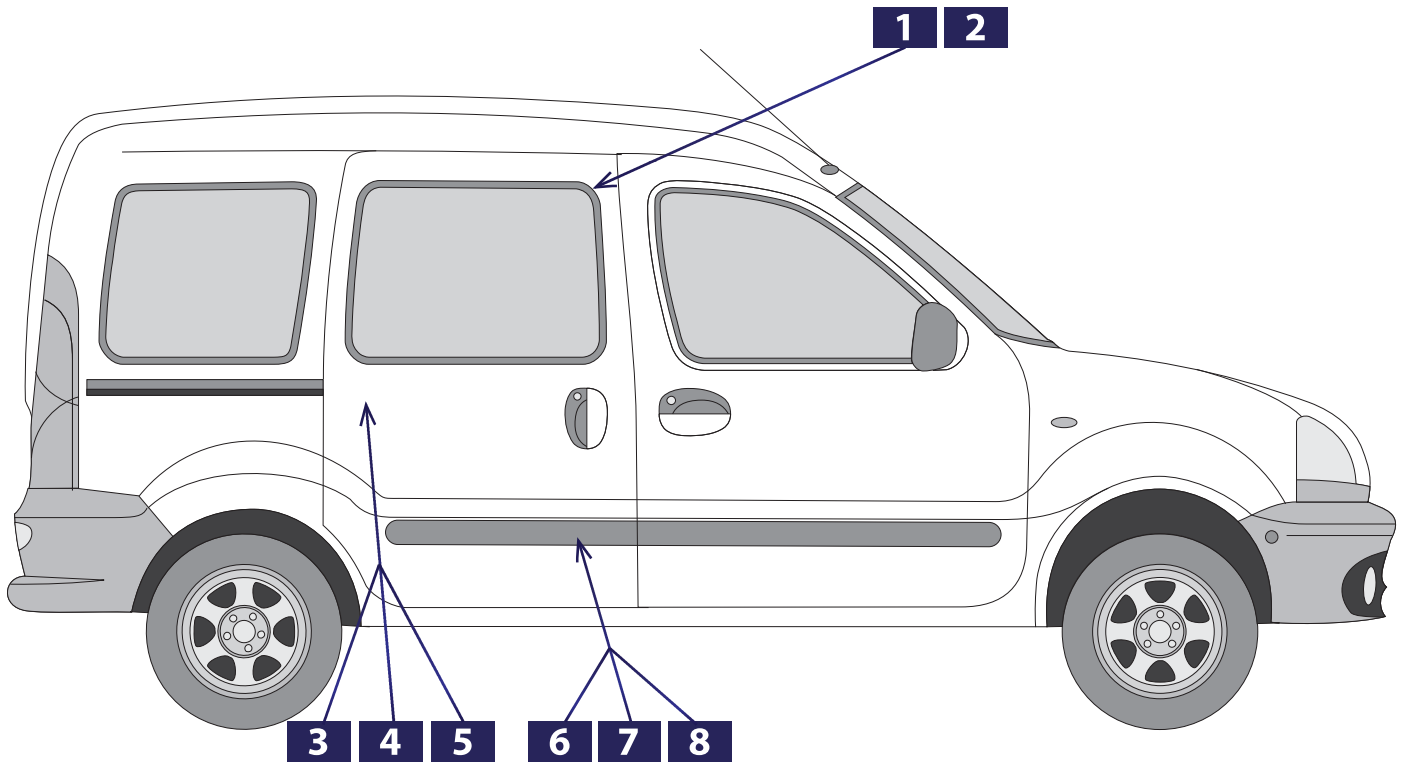

**1 FT95574**



**2 FT95543**



**3 FT95576**



**4 FT95575**



**5 FT95544**



**6 FT95578**



**7 FT95577**



**8 FT95545**



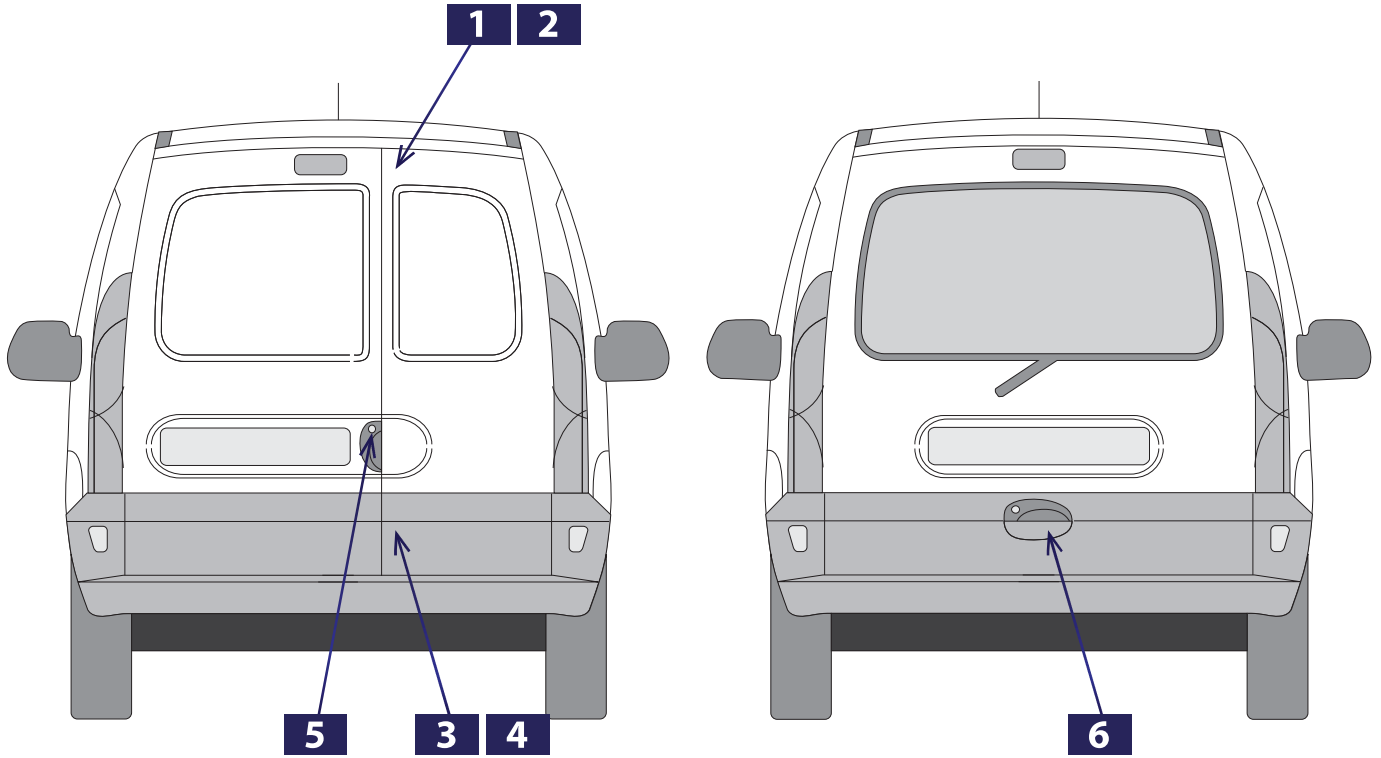

## MOVANO / INTERSTAR

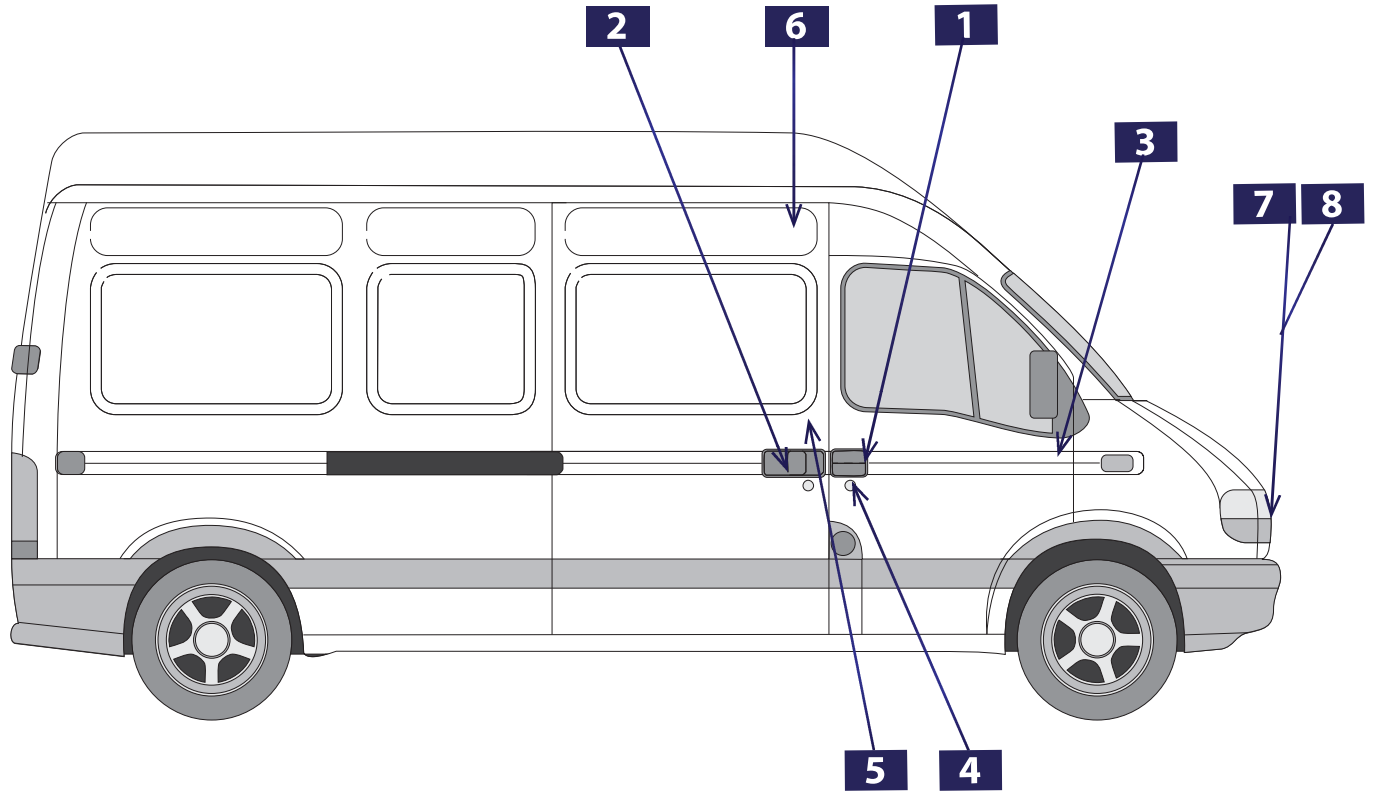

**1** FT94548 (RIGHT) //  
FT94549 (LEFT) //



**2** FT94533 //



**3** FT95455 //



**4** FT94154 //



**5** FT95458 //



**6** FT95459 //



**7** FT94160 //



**8** FT94161 //



## MOVANO / INTERSTAR

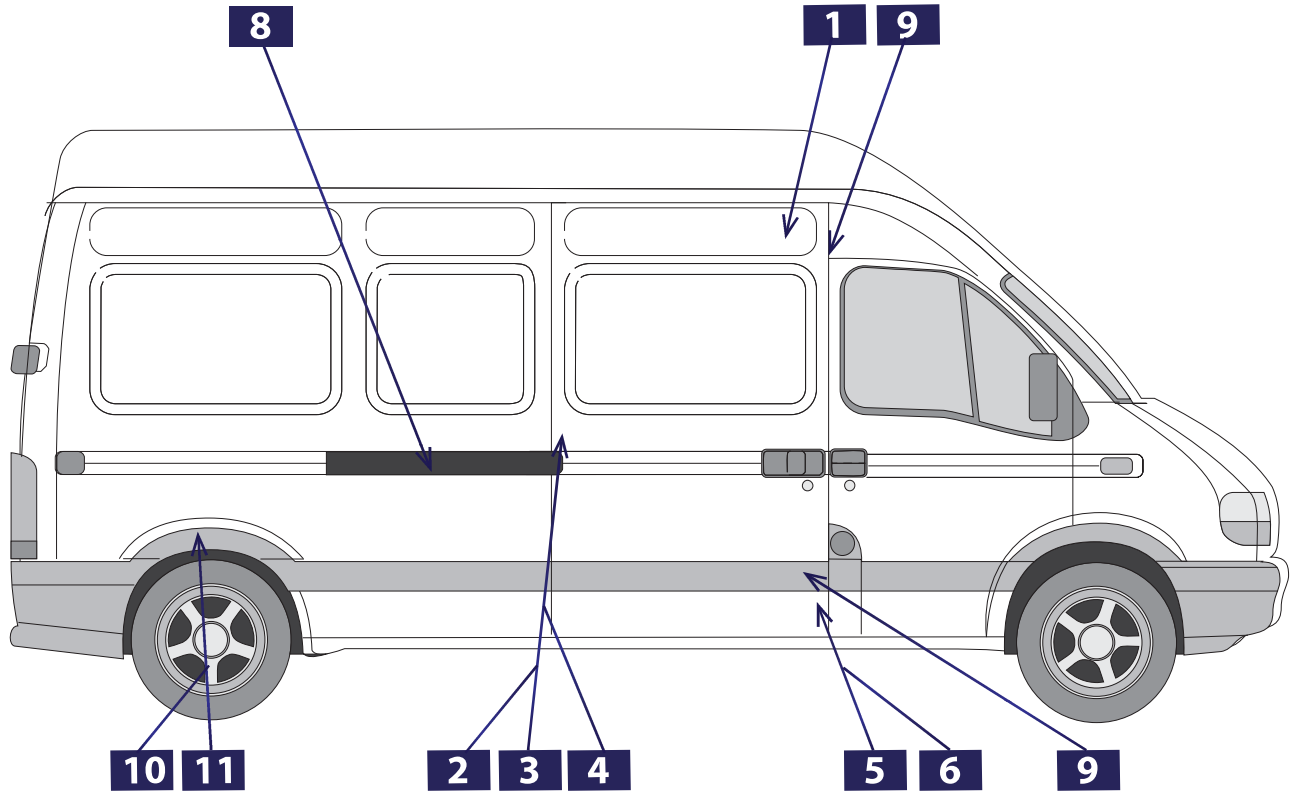

<b>1</b>   FT95535 	<b>2</b>   FT95386 	<b>3</b>   FT95538 	<b>4</b>   FT95536 
<b>5</b>   FT95385 	<b>6</b>   FT95539 	<b>1-2-5</b>   FT95504 	<b>8</b>   FT95586 
<b>9</b>   FT95457 	<b>10</b>   FT90530  <p style="text-align: center;">TRUCK SINGLE</p>	<b>11</b>   FT90531  <p style="text-align: center;">TRUCK DOUBLE</p>	

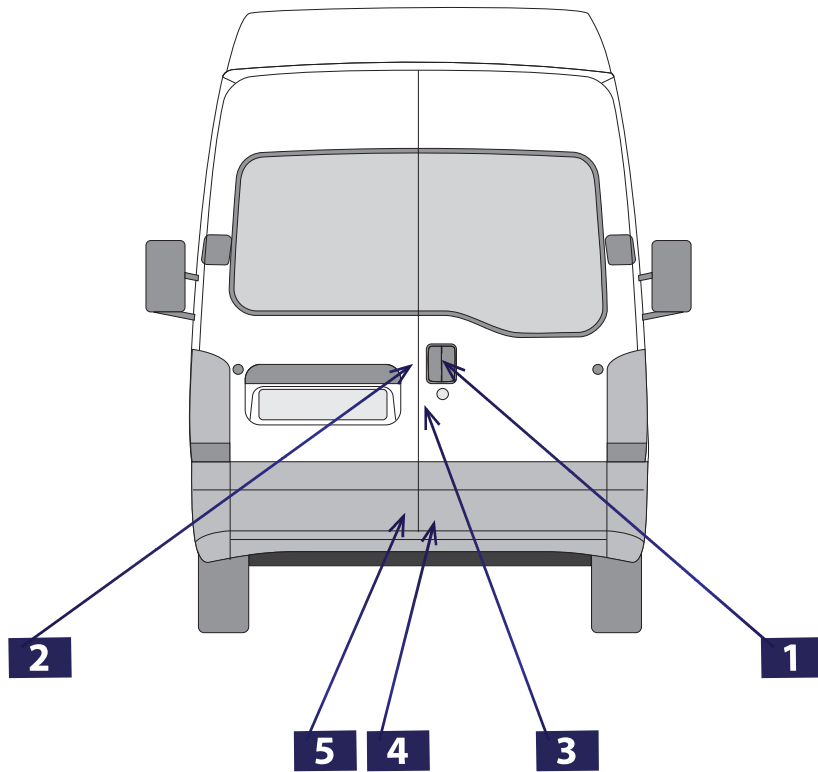

**1** FT94550



**2** FT94573



**3** FT95475



**4** FT95433



**5** FT95454





## MOVANO / INTERSTAR

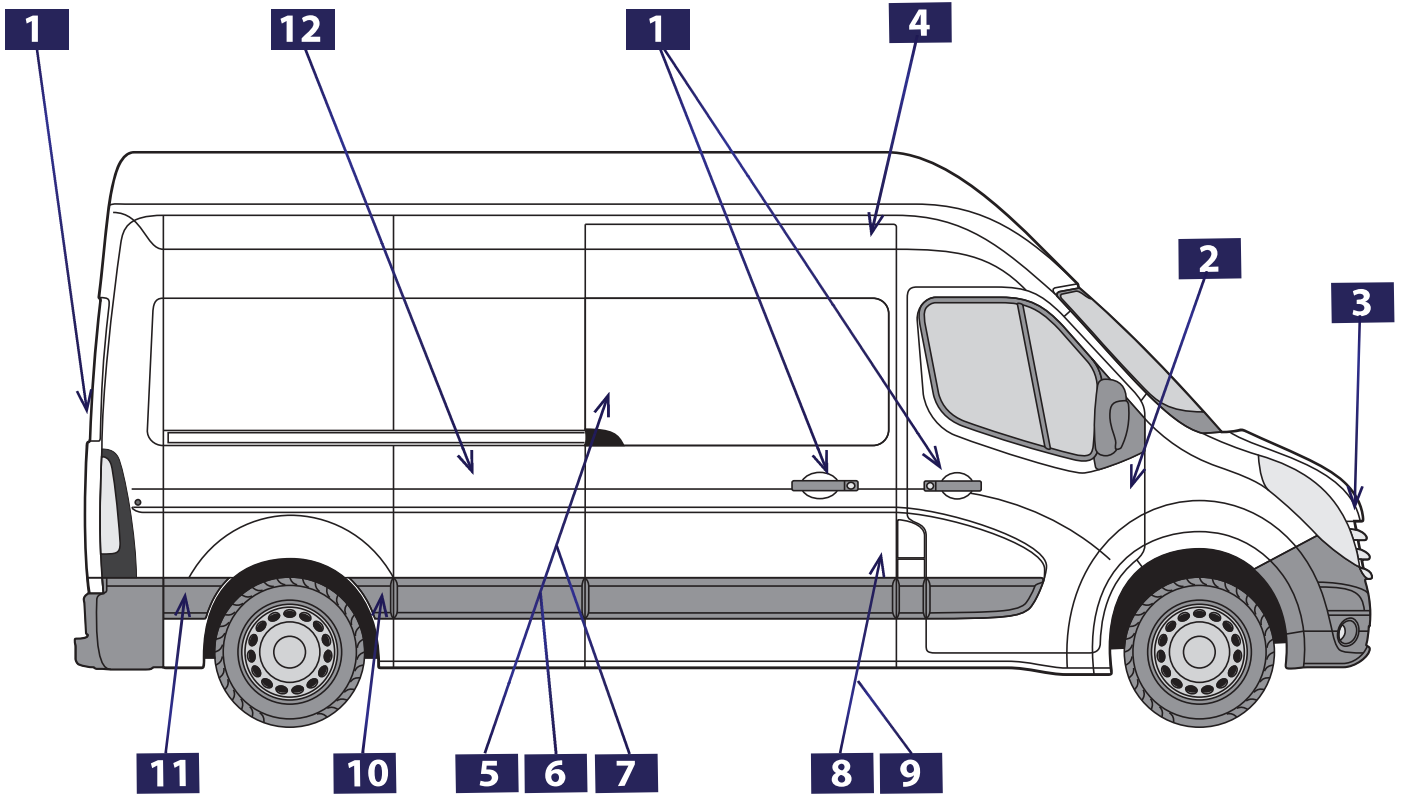

<p><b>1</b> FT94556</p>	<p><b>2</b> FT95456</p>	<p><b>3</b> FT94159</p>	<p><b>4</b> FT95521</p>
<p><b>5</b> FT95582</p>	<p><b>6</b> FT95549 (RIGHT) FT95550 (LEFT)</p>	<p><b>7</b> FT95522</p>	<p><b>8</b> FT95551</p>
<p><b>9</b> FT95523</p>	<p><b>10</b> FT90809 (RIGHT) FT90808 (LEFT)</p> <p>RIGHT / LEFT</p>	<p><b>11</b> FT90811 (RIGHT) FT90810 (LEFT)</p> <p>RIGHT / LEFT</p>	<p><b>12</b> FT90531</p> <p>TRUCK DOUBLE</p>

## VIVARO / PRIMASTAR

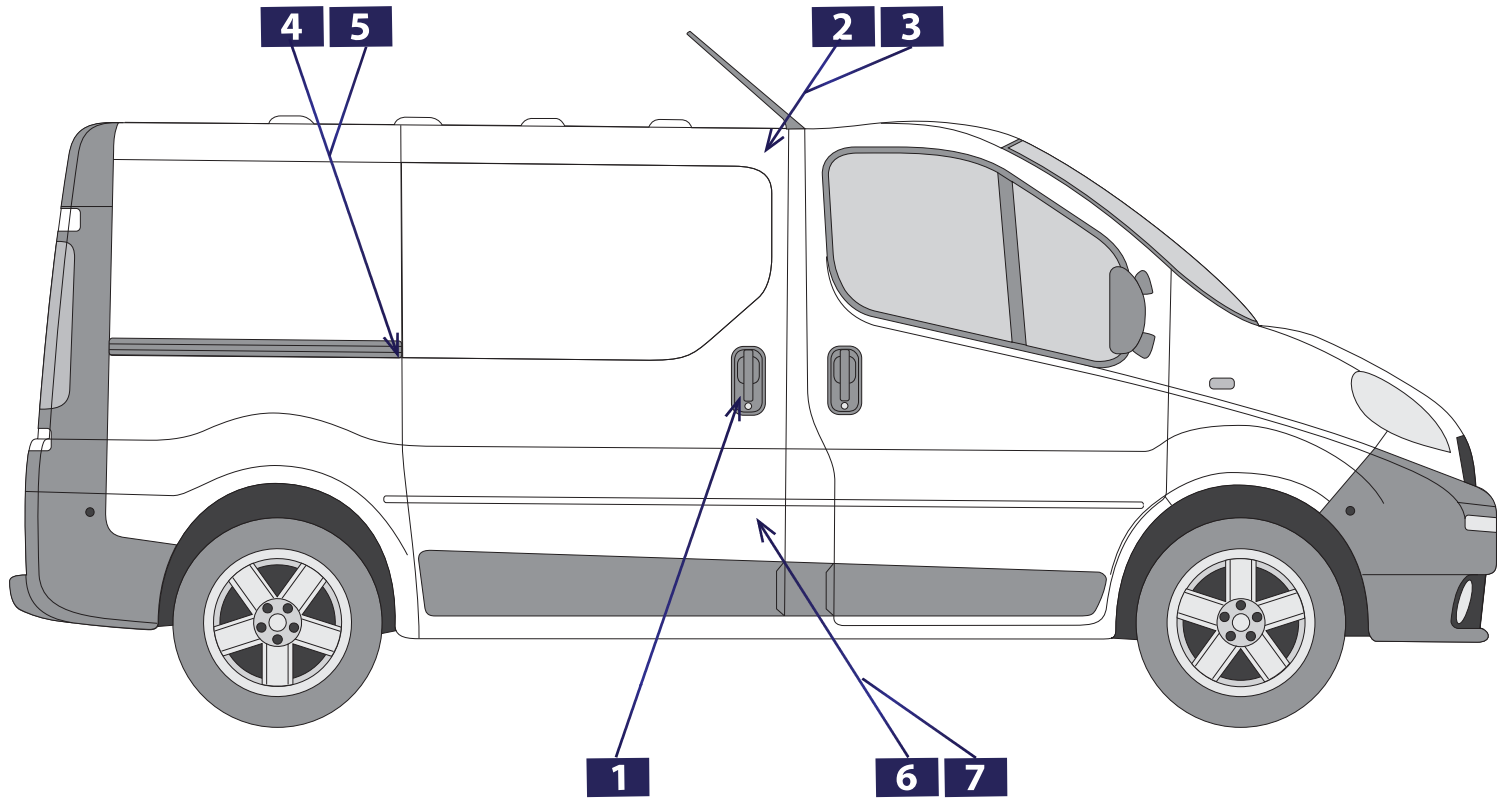

1 FT94577



2 FT95579



3 FT95546



4 FT95580



5 FT95547



6 FT95581



7 FT95548

